

2015-16
WINSTED CATALOG

Winsted®
Control Room Consoles

THE GLOBAL LEADER >>
IN CONTROL ROOM CONSOLES

NEW

DUAL SIT/STAND

WEB: winsted.com • EMAIL: info@winsted.com • TEL: 800.447.2257 • FAX: 800.421.3839



WINSTED CORPORATION

Winsted is the worldwide leader in control room console and furniture solutions. We create attractive, ergonomic consoles that interface with your operators to improve comfort and optimize efficiency. We offer stock, customized and custom consoles suitable for any application. Whether you are building a state-of-the-art control room from the ground up, or you simply need to upgrade your operations, Winsted can provide the ideal solution. Our experts combine the disciplines of industrial design, ergonomics and interior design to create solutions that reduce fatigue, improve productivity and inspire. Our commitment to customer service is second-to-none and your satisfaction is guaranteed.



PRESTIGE SERIES 4-21



WORK SURFACES 22-27



IMPULSE DUAL SIT/STAND 30-33

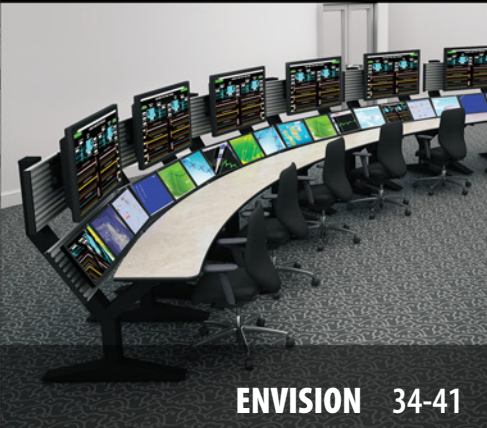

ENVISION 34-41



E-SOC 42-49



M-VIEW 50-55



VERTICAL RACKS 56-61



SPECTRUM 62-70



CUSTOM WOOD 72-81



CUSTOM DIVISION 82-93



ACCESSORIES 94-96

NEW PRODUCTS

- DATA-LINQ** 20
- AIR COMMAND** 21
- COLLABORATION TABLES** 77
- CONFERENCE ROOM TABLES** 79
- SKY TRACK** 92
- HORIZON DUAL SIT-STAND** 93
- INDEX** 97



Winsted
Control Room Consoles

PRESTIGE SERIES CONSOLES

Prestige Consoles are ergonomic, modular and adaptable, giving users flexibility in any control room environment. Prestige consoles feature the Versa-Trak monitor support system, which offers the ultimate in adjustability. Monitor viewing angles and sight lines are easily optimized based on personal needs. Prestige consoles are beautiful with a feature set second to none.



PRESTIGE
SIGHT-LINE[™]
SERIES

Our **Flagship Console** is truly one-of-kind with a world class feature set, which is complimented by an impressive appearance making it ideal for all control room applications. Sight-Line consoles are modular, reconfigurable and expandable to meet your changing needs, and can be customized in numerous ways to create a unique solution.



PRESTIGE
SLAT-WALL[™]
SERIES

Our **Slat-Wall Console** is built on the same foundation as our award winning Sight-Line console. The same world-class feature set is incorporated with slat-wall to provide added versatility and an element of privacy. The slat-wall is 15" tall and constructed of high quality extruded 6105-T5 aluminum. The black anodized finish is attractive and smooth to the touch. A variety of monitor mounts and accessories are available to mount on the slat-wall.



PRESTIGE
INSIGHT[™]
SERIES

Our **Compact Console** features a high-density profile, designed for a high performance world. Insight's overall depth of 32" saves valuable space and maximizes control room functionality. Our engineers reduced the overall depth of the chase and work surface on the popular Sight-Line console to create a compact console solution. The result is an efficient footprint that meets ergonomic standards and provides ample desktop workspace.



PRESTIGE
ASCEND[™]
SERIES

Our **Sit/Stand Console** offers three programmable height settings for ultimate versatility and optimum comfort in any control room setting. This completely redesigned sit/stand console includes electric-lift legs, which enable operators to quickly and easily adjust the work surface height from 28-1/2" to 44-1/2" with the push of a button. Two-, three- and four-leg systems are available with load capacities of 300, 450 and 600 lbs. respectively.

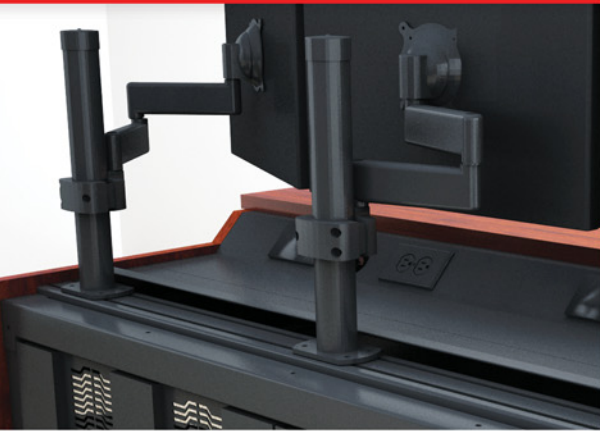

VERSA-TRAK MONITOR MOUNTING SYSTEM

Integrated horizontal aluminum track system will support a wide variety of monitor arrays. Versa-Trak offers the ultimate in versatility with easy horizontal adjustment. Post-mounted VESA brackets provide vertical adjustability along with the ability to tilt and pivot the monitors.



INTEGRATED DATA/POWER

Keep your electronics up and running. Sight-Line and Insight consoles feature openings for universal data mounting plates and duplex power outlets, conveniently located at the back of the work surface where they are within easy reach to connect electronics.



EASY-ACCESS CABLE MANAGEMENT

Enhance reliability while protecting and managing your cables. All Prestige consoles feature convenient cablemanagement solutions that are easily accessible. A large drop-down interior tray for additional cable management is also available as an option.



MULTI-PURPOSE DOORS

Double-panel front and rear doors are extra sturdy to support a CPU shelf or file/storage bin for convenient swing-out access. Prevents reaching and working in confined storage spaces.

PRODUCT FEATURES AND HIGHLIGHTS

Three Base Console Widths

Base consoles are available in three widths: 24", 48", and 72". Features the Insta-Lock fastening system for simple construction. Black powder-coat finish.

Corner Fillers

Corner fillers help fit consoles into rooms, and deliver a convenient, ergonomic wrap-around operator console. Choose from 15°, 45°, and 90° concave corner options or 15° and 45° convex corner options.

Easy-Access Cable Management

Enhance reliability while protecting and managing your cables. All Prestige consoles feature convenient cable management solutions that are easily accessible. A large drop-down interior tray is also available as an option.

Multi-Purpose Locking Doors

Double-panel doors are extra-sturdy to support a CPU shelf or file/storage bin for convenient swing-out access.

Anti-Tip Extension

Extensions stabilize the console on all in-line console configurations. Anti-tip extensions come standard with all end frames. Black powder-coat finish.

Data/Power Access

Openings for a universal data mounting plate (RJ-45, HDMI, CAT-5, CAT-5E, CAT-6, BNC, and S-Video) and/or duplex power are conveniently located at the back of the work surface on Sight-Line and Insight consoles.

Versa-Trak Monitor Mounting System

Integrated horizontal aluminum track system will support a wide variety of monitor arrays. Versa-Trak offers the ultimate in versatility with easy horizontal adjustment. Post-mounted VESA brackets provide vertical adjustability along with the ability to tilt and pivot the monitors.

Decorative TruForm End Panels

Complete the look of your console with our popular TruForm end panels. TruForm panels are available in a wide variety of colors. End panels can also be custom ordered in laminate or solid-surface materials.

Rack Mount Turret

Optional Sight-Line rack mount turrets can be positioned to meet your needs. Available in either 7" (4U), 10-1/2" (6U), or 19-1/4" (11U) by 19"W EIA rack space. Features a vented top. Decorative wood trim is available. 10-1/2" (6U) turret is available for Insight.

Adjustable Monitor Mounts

VESA-compliant pivot/tilt mounts easily attach monitors to a support post, and provides smooth pivot and pitch adjustment for optimal viewing of flat panel monitors.

Four Monitor Mount Post Heights

Available in four different heights: 15", 28-1/2", 42" and 60" so you can create a monitor array suitable for any application.

Optional M-View Monitor Wall

Sight-Line and Insight consoles work in tandem with our M-View monitor wall system to support large plasmas and/or LCD monitors over rack mount turrets.

Multiple Work Surface Options

Choose from four work surface options. Our proprietary Endurance Plus and Comfort Edge work surfaces, as well as Corian® and Marmoleum® options are available for all our consoles.

Slat-Wall Mounting System

Constructed of high quality extruded 6105-T5 aluminum, the Slat-Wall system is 15" high and designed to support a variety of monitor mounts and accessories.

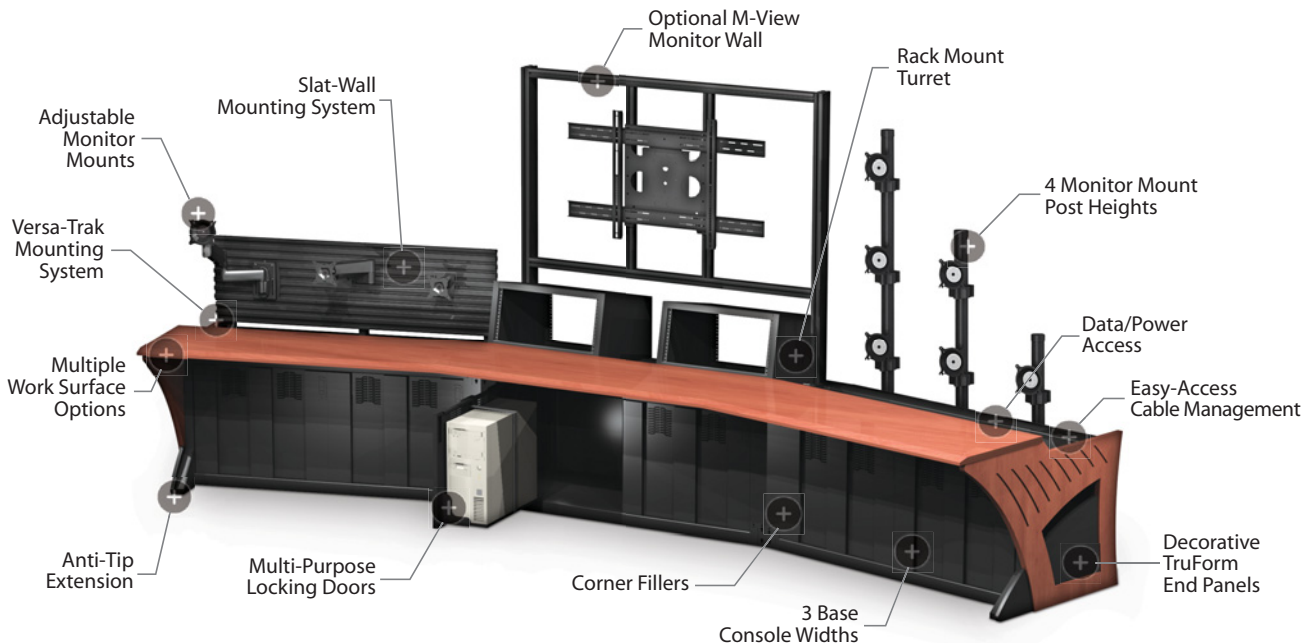



SIGHT-LINE CONSOLES

Sight-Line consoles feature our integrated Versa-Trak monitor mounting system, which offers the ultimate in adjustability. The Versa-Trak system allows users to optimize and easily modify sight lines and viewing angles based on personal needs. If you are looking for unparalleled beauty and function designed specifically for your needs, you have found the solution. Whether you need a single workstation or a complete control room, Sight-Line consoles are perfect for all installations.



SLAT-WALL CONSOLES

Our new Prestige Slat-Wall console takes flexibility to a new level. With several monitor mounts to choose from, there are virtually an infinite number of ways to configure and adjust your monitors. Eliminate clutter and add space with a selection of Slat-Wall accessories designed to keep you organized. Slat-Wall panels also enhance personal workspace by adding an element of privacy.



INSIGHT CONSOLES

Insight consoles incorporate all the features found in our popular Sight-Line console and then packages them into a compact profile that saves space and maximizes the number of operators able to staff the control room. If you are challenged for floor space, but want a fully functional console packed with features, Insight is the solution.



ASCEND CONSOLES

Keep your operators happy, healthy and productive with our Ascend sit/stand console. Changing positions throughout the day can help minimize physical stress and fatigue. Ascend provides a wide range of movement and easily allows operators to alternate between sitting and standing at the push of a button.



SINGLE-OPERATOR SIGHT-LINE CONSOLE

MODEL#	HEIGHT	WIDTH	DEPTH
W5721	28-1/2" (724mm)	78" (1981mm)	43-3/4" (1102mm)
COLOR	SIDE PANEL	WORK SURFACE	
BLACK	SHARK GREY TRUFORM	SHARK GRAY ENDURANCE PLUS	

72" Sight-Line console comes complete with four monitor mounts.



SIGHT-LINE CORNER CONSOLE WITH CREDENZA

MODEL#	HEIGHT	WIDTH	DEPTH
W5701	28-1/2" (724mm)	167-1/2" (4255mm)	80-1/2" (2045mm)
COLOR	SIDE PANEL	WORK SURFACE	
BLACK	AMERICAN NATURAL TRUFORM	AMERICAN NATURAL ENDURANCE PLUS	

Corner design provides ample space for three operators. Console includes radial credenza and three dual-mount LCD poles.



SLAT-WALL CONSOLE WITH TRUFORM DOORS

MODEL#	HEIGHT	WIDTH	DEPTH
W5830	41-1/8" (1045mm)	78" (1981mm)	43-3/4" (1111mm)
COLOR	SIDE PANEL	WORK SURFACE	
BLACK	CHERRY TRUFORM	CHERRY ENDURANCE PLUS	

This 72" console is perfect for one operator. Comes complete with three monitor mounts and TruForm doors to match sides and work surface.



SLAT-WALL CORNER CONSOLE

MODEL#	HEIGHT	WIDTH	DEPTH
W5831	41-1/8" (1045mm)	104-3/8" (2651mm)	57-1/4" (1454mm)
COLOR	SIDE PANEL	WORK SURFACE	
BLACK	CROSSFIRE JAVA TRUFORM	FIBERS CASHMERE ENDURANCE PLUS	

Corner design wraps around the operator for maximum comfort. Console includes five monitor mounts.



CURVED <u>INSIGHT</u> CONSOLE			
MODEL#	HEIGHT	WIDTH	DEPTH
W6407	28-1/2" (724mm)	95" (2413mm)	39-3/4" (1010mm)
COLOR	SIDE PANEL	WORK SURFACE	
BLACK	FUSION MAPLE TRUFORM	WESTERN TAN COMFORT EDGE	

Two 15° corners form an ergonomic wrap-around configuration.



DUAL-OPERATOR <u>INSIGHT</u> CONSOLE			
MODEL#	HEIGHT	WIDTH	DEPTH
W6408	28-1/2" (724mm)	104-7/8" (2664mm)	32-1/2" (826mm)
COLOR	SIDE PANEL	WORK SURFACE	
BLACK	FUSION MAPLE TRUFORM	AMBER PEAR ENDURANCE PLUS	

Two 48" chases create a compact console for two operators.



SINGLE-OPERATOR <u>ASCEND</u> CONSOLE			
MODEL#	HEIGHT	WIDTH	DEPTH
W5737	28-1/2" (724mm) - to - 44-1/2" (1030mm)	82" (2083mm)	40-5/8" (1032mm)
COLOR	SIDE PANEL	WORK SURFACE	
BLACK	ALMOND CHERRY TRUFORM	ALMOND CHERRY ENDURANCE PLUS	

Sitting or standing, this adjustable console will keep your operators comfortable all day.



ASCEND CONSOLE WITH PENINSULA			
MODEL#	HEIGHT	WIDTH	DEPTH
W5738	35" (889mm) - to - 44-1/2" (1030mm)	188-1/8" (4778mm)	105-7/8" (2689mm)
COLOR	SIDE PANEL	WORK SURFACE	
BLACK	AUBURN PEAR TRUFORM	AUBURN PEAR ENDURANCE PLUS	

Dual-operator Ascend console features a center peninsula with extra storage space and three rack mount turrets.

AXIOM MONITOR MOUNTS: (1.5" DIA. MOUNTING POSTS)

W6471

15" Post - Single Monitor Post Mount, Vertical



W6472

28-1/2" Post - Dual Monitor Post Mount, Vertical



W6473

42" Post - Triple Monitor Post Mount, Vertical



W6491

15" Post - Single Monitor Articulating Arm



W6492

28-1/2" Post - Single Monitor Articulating Arm



W6493

28-1/2" Post - Dual Monitor Two Articulating Arms



W6496

15" Post - Dual Monitor Mount Dual Articulating Arms



W6497

28-1/2" Post - Quad Monitor Mount Two Dual Articulating Arms



A custom monitor wall can be integrated to support your larger monitors. Contact Winsted for details.



PRESTIGE MONITOR MOUNTS: (1.9" DIA. MOUNTING POSTS)

E5081

15" Post - Single Monitor Post Mount, Vertical



W5772

28-1/2" Post - Dual Monitor Post Mount, Vertical



W5773

42" Post - Triple Monitor Post Mount, Vertical



W5777

15" Post with Dual 15" Extension Arms



W5690

Dual-Post Large Monitor Mount (Supports 42" - 63" Monitors)



W5774

15" Post with 15" Extension Arm



W5775

28-1/2" Post with 15" Extension Arm



W5776

42" Post with Two 15" Extension Arms



W5778

15" Post with Height Adjustable Arm



W5698

28-1/2" Post with VESA Mount (Supports 26" - 45" Displays)



** 60" Pole with mounts available. Contact Winsted for details.*

SLAT-WALL MONITOR MOUNTS

58171
Slat-Wall
Monitor Mount



58174
Dual-Hinge Slat-Wall
Monitor Mount



58178
Adjustable Height Slat-Wall
Monitor Mount



SLAT-WALL ACCESSORIES

PAPER TRAY

MODEL#	DIMENSIONS	WEIGHT
58160	1-3/4"H x 15"W x 9-1/2"D (44 x 381 x 241mm)	2 LBS.

Maximize your work surface with this hanging paper tray.



58160

PHONE CADDY

MODEL#	DIMENSIONS	WEIGHT
58161	1-3/4"H x 9"W x 10-3/4"D (44 x 229 x 273mm)	2 LBS.

Use this caddy to keep your phone within easy reach.



58161

VERTICAL PAPER ORGANIZER

MODEL#	DIMENSIONS	WEIGHT
58162	8"H x 6"W x 10-1/4"D (203 x 152 x 260mm)	3 LBS.

Keep papers and folders organized and out of the way with this stylish organizer.

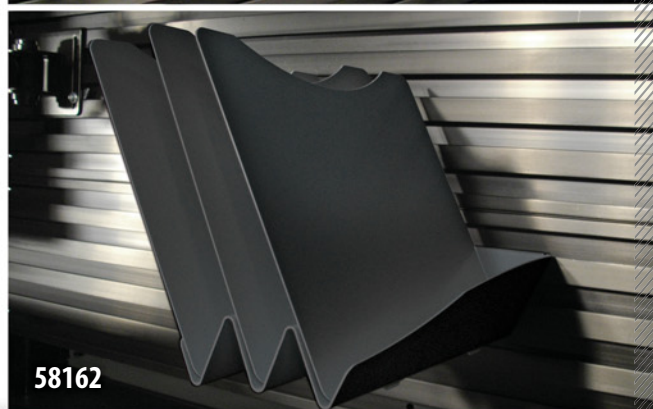

58162



RADIAL END CREENZA		
MODEL#	DESCRIPTION	WEIGHT
W5630	Left credenza for Sight-Line, Slat-Wall & Ascend	136 LBS.
W5631	Right credenza for Sight-Line, Slat-Wall & Ascend	136 LBS.
W6430	Left credenza for Insight only	110 LBS.
W6431	Right credenza for Insight only	110 LBS.

Form and function meet as the radial design provides ample storage with a stylish look. Includes work surface top.



RACK RAILS		
MODEL#	DESCRIPTION	WEIGHT
56165	19-1/4" (11U) tapped rack rails (1 Pair)	5 LBS.

Easily mounts in the front and/or rear of the 24" wide chase.

W5642	19-1/4" (11U) tapped rack rails (2 Pair) with brackets	9 LBS.
-------	--	--------

Rack mount kit for 48" and 72" chase ends.



LED TASK LIGHTS		
MODEL#	DESCRIPTION	WEIGHT
W5664	Versa-Trak mounted task light	4 LBS.
W5665	LED task light for vertical Slat-Wall	4 LBS.

Optional Task Light features a three-bar design for ultimate reach and flexibility. The ultra-adjustable LED head can spin in its socket, sweep side to side, and rotate around the end of the arm to point in any direction. Dimming is easily controlled by a touchstrip located near the LED head for easy access.

56679	LED light with magnetic base and 18" flexible neck	1 LB.
10679	LED light with VESA mount and 18" flexible neck	1 LB.

Features a 6-foot cord and allows users to switch between white or red lights.



DOOR MOUNT FILE STORAGE BIN & CPU SHELF		
MODEL#	DESCRIPTION	WEIGHT
56088	File storage bin, door mounted	6 LBS.
56087	CPU shelf, door mounted	6 LBS.

Provides convenient swing-out access to files and/or CPU. *Must be used with 56302 door, or the wood doors. Doors sold separately.



RACK MOUNT TURRETS		
MODEL#	DESCRIPTION	WEIGHT
64032	10-1/2" (6U) Rack Turret, 12° Slope (Insight Only)	20 LBS.
56030	7" (4U) Rack Turret, 45° Slope	16 LBS.
W5660	7" (4U) Rack Turret with wood trim, 45° Slope	18 LBS.
56032	10-1/2" (6U) Rack Turret, 12° Slope	23 LBS.
W5661	10-1/2" (6U) Rack Turret with wood trim, 12° Slope	25 LBS.
56036	19-1/4" (11U) Rack Turret, 12° Slope	29 LBS.

Rack mount turrets mount easily to the chase and keep electronics within reach.

56981	27" ABS chase filler (Not Shown)	1 LBS.
-------	----------------------------------	--------

Use with rack turrets to enclose unused chase openings. Can be cut to size.

WOOD PRESTIGE CONSOLE DOORS

MODEL#	DESCRIPTION	WEIGHT
56569	Locking TruForm door left-hinged	10 LBS.
56570	Locking TruForm door right-hinged	10 LBS.
56568	Locking Marmoleum door left-hinged	10 LBS.
56566	Locking Marmoleum door right-hinged	10 LBS.

Coordinate your console doors with your side panels and/or work surface. Choose from a wide variety of colors.



TELEPHONE TRAY

MODEL#	OVERALL DIMENSIONS	WEIGHT
56250	13"H x 8-1/2"W x 6-3/8"D (330 x 216 x 162mm)	4 LBS.
W6469	13"H x 8-1/2"W x 6-3/8"D (330 x 216 x 162mm)	14 LBS.

Mounts at the back of the work surface for quick and easy access to a telephone.

Adjustable phone tray designed for Versa-Trak.



ELECTRICAL

MODEL#	DESCRIPTION	WEIGHT
56264	Single Box with mounting bracket	4 LBS.
56265	Dual Box with mounting bracket	5 LBS.
W5650	Six-Outlet Strip with mounting bracket	3 LBS.

56264 & W5650 brackets mount to intermediate and/or end frames. 56265 mounts to intermediate frame only.

64264	Single Box with mounting bracket (Insight Only)	3 LBS.
51710	Six-Outlet Strip (Insight Only)	2 LBS.

Mounts to Insight intermediate and/or end frames.

56264 / 64264

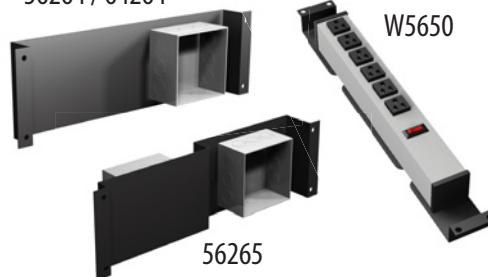

SIGHT-LINE CPU HOLDER

MODEL#	OVERALL DIMENSIONS	WEIGHT
56220	27-1/2"H x 12-1/2"W x 26"D (699 x 318 x 660mm)	45 LBS.

CPU Holder features an adjustable back and shelf. Inside dimensions are: 24-1/4"H x 9-3/8"W x 25"D (616 x 238 x 635mm). Can be positioned in-line or at the end of the console. Not compatible with Insight.



CONSOLE PARTITION

MODEL#	OVERALL DIMENSIONS	WEIGHT
W5900	18"H x 2"W x 26-1/2"D (457 x 51 x 673mm) - SIGHT-LINE	12 LBS.
W6500	18"H x 2"W x 21-1/2"D (457 x 51 x 546mm) - INSIGHT	10 LBS.

This stylish cloth partition helps create a private work space. The panel is affixed to a pole that is mounted on the Versa-Trak so it can be positioned where needed and easily moved. Constructed with a low density fiberboard core wrapped with a steel outer frame. Medium grey material.

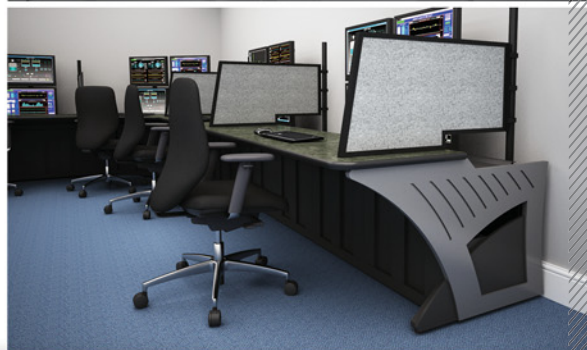



10767



W5780



64100



64074



56029

THREE DRAWER FILE CABINETS - BLACK

MODEL#	DIMENSIONS	WEIGHT
10767	27"H x 15"W x 20-7/8"D (686 x 381 x 530mm) - SIGHT-LINE	73 LBS.
10765	27"H x 15"W x 17-1/2"D (686 x 381 x 446mm) - INSIGHT	70 LBS.

Compact cabinet fits neatly under a work surface for storage of files in the bottom drawer. Middle drawer is perfect for items that are 4" high and top drawer works well for paper, pens and pencils. Plastic sliding pencil tray comes with cabinet.

10764	12"H x 14-3/4"W x 17"D (305 x 375 x 432mm)	14 LBS.
-------	--	---------

Converts the 10767 and 10765 from a three drawer cabinet to a two drawer file cabinet. 10764 replaces the two box drawers that come standard with 10767 & 10765.

PRESTIGE UTILITY SHELF

MODEL#	DIMENSIONS	WEIGHT
W5780	15"H x 22"W x 18"D (381 x 559 x 457mm)	20 LBS.
W5781	28-1/2"H x 32"W x 16"D (724 x 813 x 406mm)	25 LBS.

Add storage space and keep your work space clean and organized with this functional utility shelf. Shelf is affixed to poles that are mounted on the Versa-Trak so it can be positioned where needed and easily moved. W5780 features steel construction with black power coat paint. W5781 features laminated wood construction.

PRESTIGE LIFT-OFF PANEL

MODEL#	DESCRIPTION	WEIGHT
64100	Lift-off panel	9 LBS.

Lift off panel mounts to the front or the rear of any Prestige console and features a static latch for closure and easy removal.

INTERNAL CABLE TRAY

MODEL#	DESCRIPTION	WEIGHT
64072	Internal cable tray for 24"W base console	5 LBS.
64074	Internal cable tray for 48"W base console	9 LBS.
64076	Internal cable tray for 72"W base console	12 LBS.

Internal cable tray offers a large surface area for mounting cables and routing wires. Features four spring hinges for easy installation and repositioning. Works with all Prestige consoles. Can be mounted horizontally, front-to-back in Insight. Must be mounted vertically or at an angle in Sight-Line, Slat-Wall and Ascend. Can not be used with optional rack rails.

17-1/2" (10U) PRESTIGE RACK CABINET

MODEL#	DIMENSIONS	WEIGHT
56029	19-3/16"H x 23-3/4"W x 12"D (487 x 603 x 305mm)	40 LBS.

Welded rack mounts directly to the front frame of any Prestige console. Features spring pins for easy installation and repositioning, vented sides for cooling and all steel construction for durability. Black textured powder-coat finish.



SIGHT-LINE

SLAT-WALL

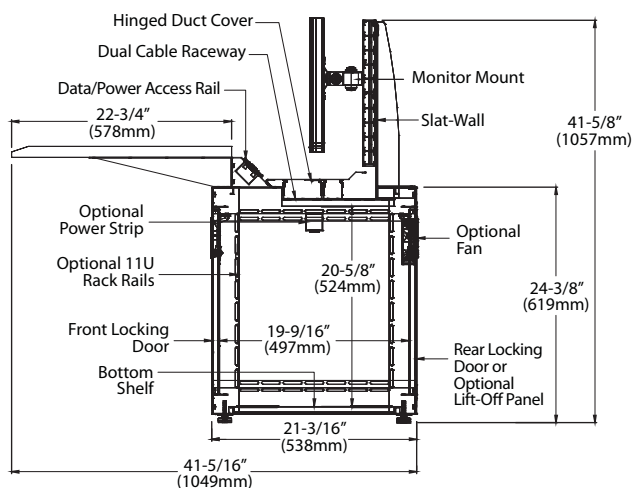
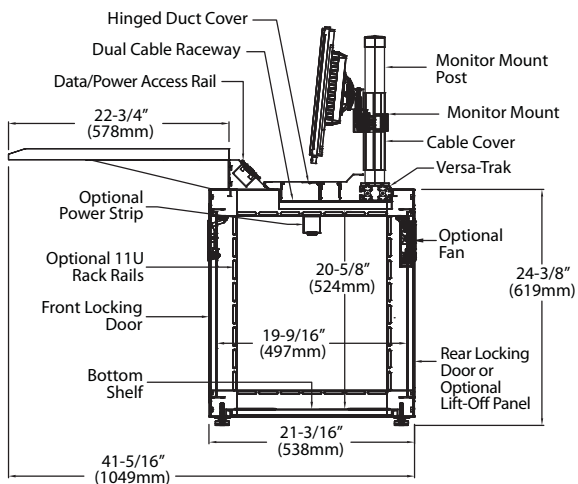

INSIGHT

ASCEND

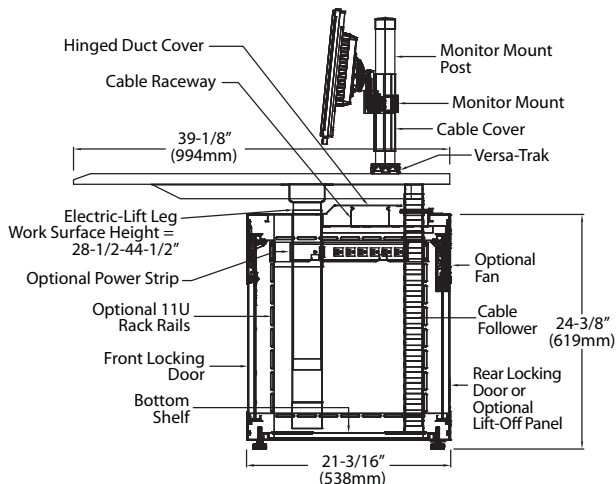
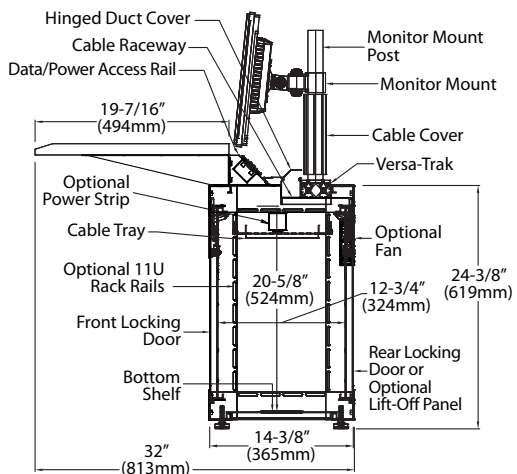

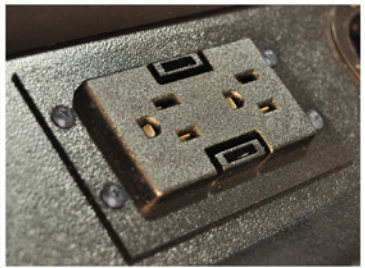

DUPLEX OUTLET INSTALLED

DYNA-LINQ™ MODULAR ELECTRICAL SYSTEM

SMART BOX



56730 - Smart Box



JUMPER CORD



56721 - 26"
56726 - 34"
56728 - 48"



DUPLEX OUTLET



56720 - Outlet
56115 - Mounting Plate

ENERGIZE YOUR CONSOLE

Dyna-Linq is a simple, flexible "plug and play" electrical system designed to power your Winsted Sight-Line or Insight console. Dyna-Linq is UL 962 approved and provides a modular, expandable and reconfigurable electrical system that doesn't require an electrician to install. Simply plug it into any standard outlet. **It couldn't be more convenient!**

HOW IT WORKS

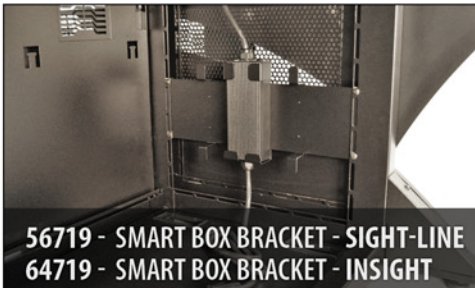

56719 - SMART BOX BRACKET - SIGHT-LINE
64719 - SMART BOX BRACKET - INSIGHT

- Each Smart Box powers up to 8 Duplex Outlets
- Mount the outlets in the desired locations on the console
- Connect Jumper Cords to the outlets and link together
- Connect Smart Box anywhere in the run of outlets
- Plug the Smart Box into any standard wall outlet

If you purchase a Dyna-Linq system with your console, Winsted will waive the installation charge and install it for **free** prior to shipping!



AIR COMMAND

PERSONAL ENVIRONMENTAL CONTROL SYSTEM

CLIMATE CONTROL UNIT



CONTROLLER AND VENT



56751 - SINGLE BAY - SIGHT-LINE & INSIGHT
56752 - DOUBLE BAY - SIGHT-LINE & INSIGHT

56754 - SINGLE BAY ASCEND CONSOLE
56755 - DOUBLE BAY ASCEND CONSOLE

CLIMATE CONTROL AT YOUR FINGERTIPS

Designed exclusively for our Prestige Series consoles, Air Command is a personal environmental control system that is convenient and easy to use. Now your operators can adjust the temperature to suit their own personal preferences. The Air Command system offers three fan speeds to circulate heated or ambient air. The system also cleans the air with a washable, replaceable, open-cell foam filter. The work surface vents are directionally adjustable and there is also an adjustable vent on the climate control unit mounted below the work surface. The 500 watt heater can raise the ambient temperature around the operator 30 degrees. The system will automatically shut off after 2 hours.



MARMOLEUM® WORK SURFACES

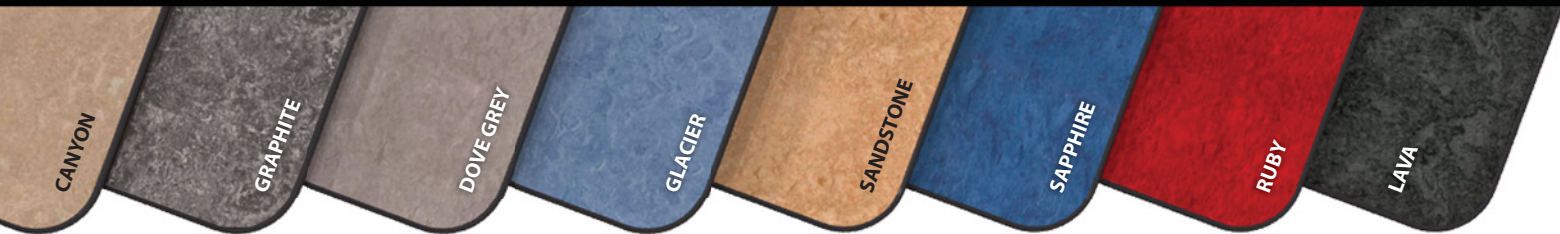

MARMOLEUM®

The durable and environmentally friendly Marmoleum® surface is made of natural products, emits no volatile organic compounds and is 100% biodegradable. Marmoleum is also impact, chemical and fire resistant with antibacterial and anti-static properties. Featuring our new Safeguard edge, Marmoleum work surfaces are a great choice for any control room.

MARMOLEUM® FEATURES

- Marmoleum is sustainable, made from natural ingredients and is 100% biodegradable
- Colors and patterns permeate through the Marmoleum surface to reduce noticeable wear
- Surface emits no volatile organic compounds
- Impact, chemical and heat resistant
- Antistatic and antibacterial properties
- Safeguard Edge provides exceptional durability



MARMOLEUM® WORK SURFACE

The sample Colors, Stains, Grains, and Finishes shown may vary slightly from actual product samples. If necessary, please request an actual product sample.



ENDURANCE PLUS™ WORK SURFACES



ENDURANCE PLUS

Through a proprietary process, we insert a continuous protective bumper material in the front edge of the work surface. This protective bumper significantly increases the durability of the work surface, which is often subject to heavy physical stress in 24/7 control room environments.

ENDURANCE PLUS FEATURES

- Continuous protective bumper inserted in the front edge for improved durability
- Ability to produce multidimensional profiles for comfortable edges and aesthetics
- Easily conforms to three-dimensional surfaces
- Easy to clean with soap and water
- Reduces visible seams
- Broad range of colors



ENDURANCE PLUS WORK SURFACE

The sample Colors, Stains, Grains, and Finishes shown may vary slightly from actual product samples. If necessary, please request an actual product sample.



COMFORT EDGE™ WORK SURFACES



COMFORT EDGE

Our urethane Comfort Edge work surface offers the ultimate in flexibility and durability. The black urethane edge is molded to 1-1/8" laminated medium density fiberboard and is available in a wide variety of colors. The Comfort Edge work surface features a smooth, contoured profile to improve operator comfort and maximize productivity.

COMFORT EDGE FEATURES

- Permanently bonded black urethane creates a long-lasting, water-tight seam with a smooth finish
- Ergonomic profile provides comfort and reduces the risk of injury due to sharp edges
- Antibacterial and antifungal additives promote a healthy work environment
- UV resistant urethane will not change color or deteriorate over time
- Suitable for the most demanding 24-7 control room operations
- Available with laminate or Marmoleum surface



COMFORT EDGE WORK SURFACE

The sample Colors, Stains, Grains, and Finishes shown may vary slightly from actual product samples. If necessary, please request an actual product sample.

COMFORT EDGE: LAMINATE COLOR OPTIONS

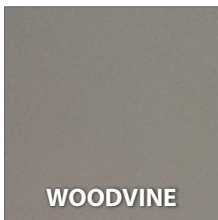
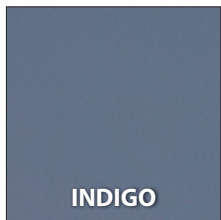
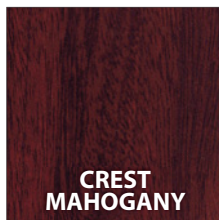
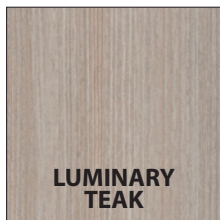
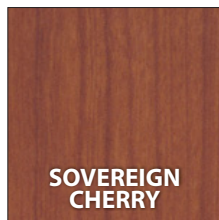
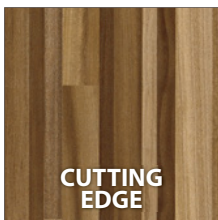
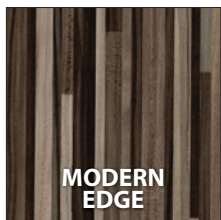
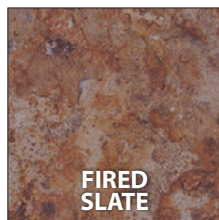
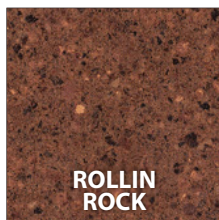
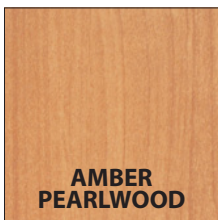
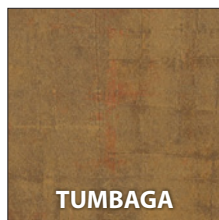
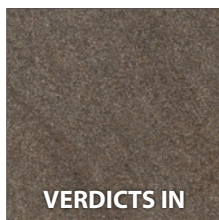
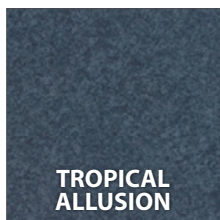
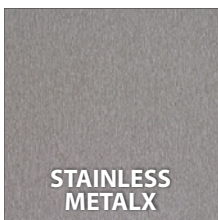
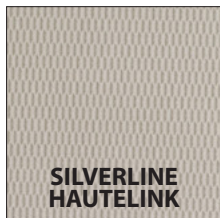



CORIAN® WORK SURFACES



CORIAN®

Corian® work surfaces are durable and feature an attractive, seamless appearance. The solid colors penetrate through the entire thickness of the material so blemishes are easily repaired. The smooth, nonporous finish is hygienic and easy to clean, while being resistant to liquids and heat.

CORIAN® FEATURES

- Whatever the spill, Corian® is easy to clean and stain resistant because liquid cannot penetrate the surface
- Corian's durability and renewability with common abrasive cleaners reduces the need for replacement, which makes Corian inherently environmentally friendly
- Joints are unobtrusive and impermeable with a seamless appearance
- Colors and patterns penetrate through the surface and cannot wear away
- Corian is inert, nontoxic, chemically unreactive, hypoallergenic and fire resistant
- Advanced blend of natural minerals and acrylic polymer
- Corian's nonporous surface is very hygienic



CORIAN® WORK SURFACE

The sample Colors, Stains, Grains, and Finishes shown may vary slightly from actual product samples. If necessary, please request an actual product sample.

CORIAN: COLOR OPTIONS

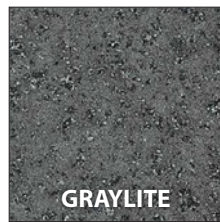
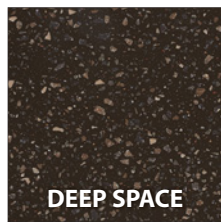
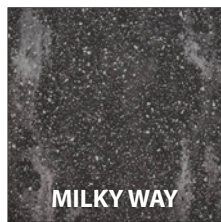
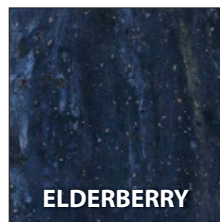
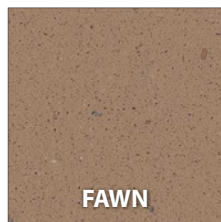
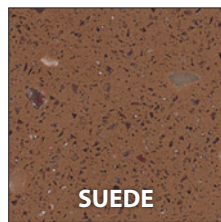
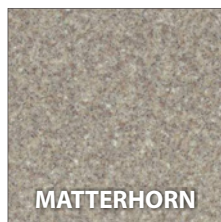
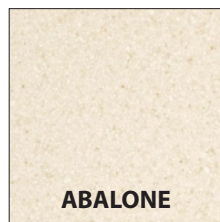
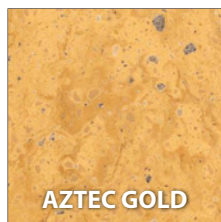
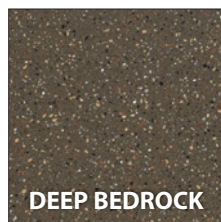



CUSTOM END PANEL GRAPHICS

Our custom graphics are printed with the highest quality inks, which produce very bright and vibrant colors that stand the test of time. The graphics are printed on a durable, premium-grade large format digital film with a UV protectant laminate. Have your console stand out today with BIG IMPACT!

CUSTOM END PANEL GRAPHICS



ROUTERED PANEL WITH LOGO



SOLID PANEL WITH LOGO

SHOW YOUR IDENTITY

Add personality to your control room. We offer simple logo decals or complete end panel wraps with custom graphics. Contact Winsted for details.

EXAMPLES:





IMPULSE DUAL SIT/STAND CONSOLES

We are meant to move! Sit/stand consoles are a great choice for an ergonomic upgrade. Impulse Consoles take ergonomics and operator comfort to a whole new level by offering two independently adjustable, ergonomically curved work surfaces. Studies have shown that too much sitting can be detrimental to your health. Movement throughout the day is important to maintaining good health. Alternating between sitting and standing is a healthy activity that increases energy and reduces fatigue. Sit/stand consoles also provide adjustability to meet the needs of each individual operator.

PRODUCT FEATURES AND HIGHLIGHTS

Safeguard Edge Work Surface

Impulse consoles come standard with a durable, high pressure Graphite Nebula laminated work surface featuring our proprietary Safeguard Edge.

Versa-Trak Monitor Mounting System

Integrated horizontal aluminum track system will support a wide variety of monitor arrays. Versa-Trak offers the ultimate in versatility with easy horizontal adjustment. Post-mounted VESA brackets provide vertical adjustability along with the ability to tilt and pivot the monitors.

Electric-Lift Legs

Quickly and easily adjust the work surface height from 30" to 46" at the push of a button and offers three programmable height settings. Each work surface has a load capacity of 520 lbs.

Adjustable Monitor Mounts

VESA-compliant pivot/tilt mounts easily attach monitors to a support post, and provides smooth pivot and pitch adjustment for optimal viewing of flat panel monitors.

Perforated Privacy Panel

Decorative, perforated privacy panel conceals cables, enhances the look of the console and adds an element of privacy for the operator.

Easy-Access Cable Management

Enhance reliability while protecting and managing your cables. All Impulse consoles feature a large cable channel incorporated into the modesty panel. In addition, there are four vertical cable carriers that travel with the work surfaces.

Three Monitor Mount Post Heights

Available in three different heights: 15", 28-1/2", and 42" so you can create a monitor array suitable for any application.

CPU Pedestal

CPU pedestal with leg levelers mounts to the inside of the leg and features two slots for adjustable Velcro™ straps to keep your CPU safe and secure.

Decorative End Panels (Optional)

Complete the look of your console with our popular TruForm end panels, which are available in a wide variety of colors. Optional end panels can also be custom ordered in laminate or solid-surface materials.

Powder-Coat Paint

The Impulse infrastructure is coated with a durable black powder-coat paint that accentuates the work surface. Textured finish prevents fingerprints and lasts for years.





B3210



B3230

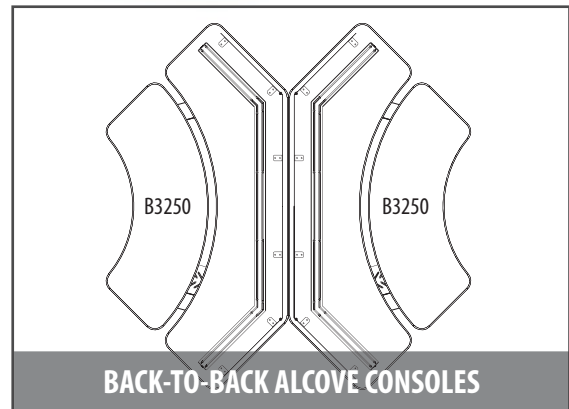
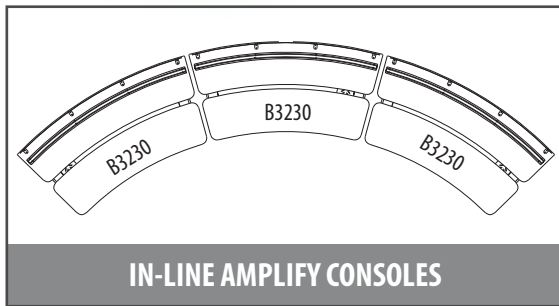

B3250

IMPULSE DUAL SIT/STAND CONSOLES

MODEL#	WORK SURFACE HEIGHT	WIDTH	DEPTH
B3210	30"-46" (762-1168mm)	75-3/4" (1924mm)	44-5/8" (1133mm)
Impulse Paradigm console sets the standard.			
B3230	30"-46" (762-1168mm)	90-9/16" (2300mm)	46" (1168mm)
Impulse Amplify console offers an extra-large work area.			
B3250	30"-46" (762-1168mm)	96-1/2" (2451mm)	48" (1219mm)

Impulse Alcove console features a compact 90° corner configuration.

All Impulse consoles feature two independently adjustable, ergonomically curved work surfaces. Each work surface adjusts from 30" to 46" high at the touch of a button. Both work surfaces feature two electric-lift legs and can support 520 pounds. All standard Impulse consoles include Graphite Nebula laminated work surfaces with our proprietary Safeguard Edge. Consoles can be used as stand-alone work stations, or combined to create a custom configuration.

AXIOM MONITOR MOUNTS: (1.5" DIA. MOUNTING POSTS)

W6471
15" Post - Single Monitor
Post Mount, Vertical



W6472
28-1/2" Post - Dual Monitor
Post Mount, Vertical



W6473
42" Post - Triple Monitor Post
Mount, Vertical



W6491
15" Post - Single Monitor
Articulating Arm



W6492
28-1/2" Post - Single Monitor
Articulating Arm



W6493
28-1/2" Post - Dual Monitor
Two Articulating Arms



W6496
15" Post - Dual Monitor Mount
Dual Articulating Arms



W6497
28" Post - Quad Monitor Mount
Two Dual Articulating Arms



W6469
Adjustable Phone Tray
Mounts to Versa-Trak



IMPULSE ACCESSORIES

POWER SUPPLY OUTLET

MODEL#	DESCRIPTION	AMP	CORD LENGTH	WEIGHT
10710	34" - Ten-outlet	15	72" (1829mm)	4 LBS.

Lighted on/off switch. Mounts horizontally to the underside of the rear work surface.



CPU PEDESTAL

MODEL#	DESCRIPTION	WEIGHT
32087	CPU Pedestal - 8"W x 19-1/2"D (203 x 495mm)	5 LBS.
12765	Velcro Strap 1"x 96" long (25 x 2438mm)	0.5 LBS.

CPU pedestal with leg levelers mounts to the inside of the leg and features two slots for adjustable Velcro straps (Part# 12765).



13-3/4" WIDE PENCIL DRAWER - BLACK

MODEL#	DIMENSIONS	WEIGHT
55233	2-3/8"H x 13-3/4"W x 18"D (60 x 349 x 457mm)	4 LBS.

Mounts to the under-side of the work surface. Pulls out 12-3/4" (324mm). Black formed plastic.





ENVISION COMMAND CONSOLES

Winsted's NEW EnVision Command Console is the next-generation console built for today's technology. A progressive new modular design offers the perfect balance of form, function and ergonomics suitable for any control room application large or small.

PRODUCT FEATURES AND HIGHLIGHTS

Multiple Configurations

EnVision comes standard in 42", 60" and 84" widths and can be designed as a single, double or triple tier configuration. Each tier can support single or dual Slat-Wall sections for a track height of 7-1/2" or 15". Combine multiple widths with your choice of corner angles to create the perfect solution.

Multiple Work Surface Options

Choose from four work surface options: Our proprietary Endurance Plus and Comfort Edge work surfaces, as well as Corian® and Marmoleum® are available for all our consoles. We offer durable work surface configurations suitable for all control room environments, no matter how demanding.

Adjustable Monitor Mounts

VESA-compliant pivot/tilt mounts easily attach monitors to the Slat-Wall and provide smooth pivot and pitch adjustment for optimal viewing angles and ergonomic sight lines.

Slat-Wall Accessories

Put the finishing touches on your console and maximize it's functionality with a wide variety of accessories specifically designed to mount on EnVision's Slat-Wall.

Removable Rear Access Panels

EnVision's support legs feature full-length removable rear access panels to provide quick, easy access to cables for simple installation and reduced maintenance time.

Extra-Deep Rear Cable Tray

Cable management should be convenient and flexible. EnVision Command Consoles come standard with a cable trough that simply hooks onto the Slat-Wall, no tools required. Place the cable trough where you need it and you'll have fast, easy access for installation, maintenance and upgrades. The extra-deep design allows room for power outlets and large cable bundles on integrated lacing loops.

Work Surface Cable Tray

Located where you work the most, the integrated cable tray located behind the work surface keeps your work area clean and organized while protecting and organizing your wires and cables.

Adjustable CPU Holder

CPU mount provides easy access to the front and rear of your computer system. The articulating mount extends forward, includes a 90° swivel, and fits CPUs from 13-1/2" to 21-1/2"H by 5-3/8" to 9-3/8"W.

Powder-Coat Paint

EnVision's steel infrastructure is coated with a durable black powder-coat paint that accentuates the work surface and Slat-Wall. The elegant textured finish prevents fingerprints and provides uncompromising durability.

Slat-Wall Mounting System

Constructed of high-quality extruded 6105-T5 aluminum, the Slat-Wall system can be designed as a 7-1/2" or 15" high solution designed to support a variety of monitor mounts and convenient accessories. Multiple mounting positions on each tier means the Slat-Wall can be positioned exactly where you need it.

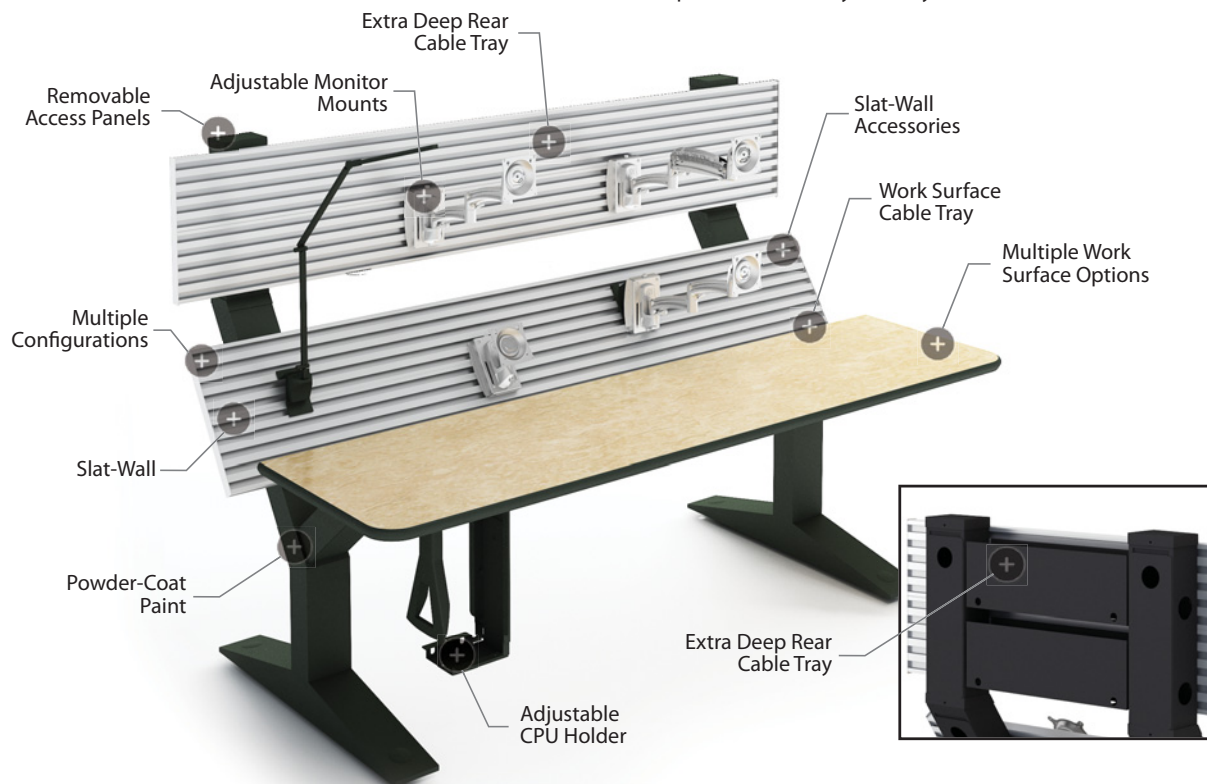



ENVISION

COMMAND CONSOLES

TAKE COMMAND

Winsted's NEW EnVision Command Console is the next-generation console built for today's technology. A progressive new modular design offers the perfect balance of form, function and ergonomics suitable for any control room application large or small. EnVision features a modern, open architecture design without the limitations of predefined corner angles. EnVision is available as a single, double or triple tier modular solution that can be expanded as needs and technology change. In any configuration, your sight lines and viewing angles will be ergonomically correct and your operators will be comfortable and productive.

FEATURES

- Modern Ergonomic Design
- No Predefined Corner Angles
- Unlimited Corner Configurations
- Easily Expandable
- Flexible Slat-Wall Mounting
- Optimized Sight Lines





B3047

PRECONFIGURED ENVISION CONSOLES

MODEL#	DESCRIPTION	OVERALL DIMENSIONS	COLOR
B3013	42" WIDE - SINGLE TIER WITH 7-1/2" H SLAT-WALL	40-1/8" H x 42" W x 43-5/8" D (1019 x 1067 x 1108mm)	BLACK WITH SILVER SLAT-WALL
B3015	60" WIDE - SINGLE TIER WITH 7-1/2" H SLAT-WALL	40-1/8" H x 60" W x 43-5/8" D (1019 x 1524 x 1108mm)	BLACK WITH SILVER SLAT-WALL
B3017	84" WIDE - SINGLE TIER WITH 7-1/2" H SLAT-WALL	40-1/8" H x 84" W x 43-5/8" D (1019 x 2134 x 1108mm)	BLACK WITH SILVER SLAT-WALL
B3023	42" WIDE - SINGLE TIER WITH 15" H SLAT-WALL	40-1/8" H x 42" W x 43-5/8" D (1019 x 1067 x 1108mm)	BLACK WITH SILVER SLAT-WALL
B3025	60" WIDE - SINGLE TIER WITH 15" H SLAT-WALL	40-1/8" H x 60" W x 43-5/8" D (1019 x 1524 x 1108mm)	BLACK WITH SILVER SLAT-WALL
B3027	84" WIDE - SINGLE TIER WITH 15" H SLAT-WALL	40-1/8" H x 84" W x 43-5/8" D (1019 x 2134 x 1108mm)	BLACK WITH SILVER SLAT-WALL
B3033	42" WIDE - DOUBLE TIER WITH 7-1/2" H SLAT-WALL	57-1/8" H x 42" W x 43-5/8" D (1451 x 1067 x 1108mm)	BLACK WITH SILVER SLAT-WALL
B3035	60" WIDE - DOUBLE TIER WITH 7-1/2" H SLAT-WALL	57-1/8" H x 60" W x 43-5/8" D (1451 x 1524 x 1108mm)	BLACK WITH SILVER SLAT-WALL
B3037	84" WIDE - DOUBLE TIER WITH 7-1/2" H SLAT-WALL	57-1/8" H x 84" W x 43-5/8" D (1451 x 2134 x 1108mm)	BLACK WITH SILVER SLAT-WALL
B3043	42" WIDE - DOUBLE TIER WITH 15" H SLAT-WALL	57-1/8" H x 42" W x 43-5/8" D (1451 x 1067 x 1108mm)	BLACK WITH SILVER SLAT-WALL
B3045	60" WIDE - DOUBLE TIER WITH 15" H SLAT-WALL	57-1/8" H x 60" W x 43-5/8" D (1451 x 1524 x 1108mm)	BLACK WITH SILVER SLAT-WALL
B3047	84" WIDE - DOUBLE TIER WITH 15" H SLAT-WALL	57-1/8" H x 84" W x 43-5/8" D (1451 x 2134 x 1108mm)	BLACK WITH SILVER SLAT-WALL

In stock and ready to ship with Graphite Nebula laminate work surface with Safeguard edge. Monitor mounts sold separately.



THREE-POSITION ENVISION CONSOLE			
MODEL#	HEIGHT	WIDTH	DEPTH
B3062	40-1/8" (1019mm)	122" (3099mm)	122" (3099mm)
COLOR	WORK SURFACE COLOR	SLAT-WALL	
BLACK	RUST MARMOLEUM SAFEGUARD EDGE	SINGLE-TIER 15" HIGH	

Three-Position EnVision Console comes complete with six pivot/tilt monitor mounts and three radial credenzas for ample storage.



DUAL-WING ENVISION CONSOLE			
MODEL#	HEIGHT	WIDTH	DEPTH
B3063	57-1/8" (1451mm)	145" (3683mm)	66" (1676mm)
COLOR	WORK SURFACE COLOR	SLAT-WALL	
BLACK	DOVE GREY MARMOLEUM SAFEGUARD EDGE	SINGLE & DOUBLE TIER 7-1/2" HIGH	

Dual-Wing EnVision Console features a single-tier center section for open monitor wall viewing. Comes complete with nine pivot/tilt monitor mounts (75x75mm/100x100mm).



ENVISION CORNER CONSOLE			
MODEL#	HEIGHT	WIDTH	DEPTH
B3064	57-1/8" (1451mm)	135" (3429mm)	93" (2362mm)
COLOR	WORK SURFACE COLOR	SLAT-WALL	
BLACK	SANDSTONE MARMOLEUM SAFEGUARD EDGE	DOUBLE-TIER 15" HIGH	

EnVision Corner Console comes complete with two 4U Rack Cabinets, three Task Lights, six Articulating Monitor Arms and eight pivot/tilt monitor mounts.



CONVEX ENVISION CONSOLE			
MODEL#	HEIGHT	WIDTH	DEPTH
B3061	40-1/8" (1019mm)	140" (3556mm)	52" (1321mm)
COLOR	WORK SURFACE COLOR	SLAT-WALL	
BLACK	GLACIER MARMOLEUM SAFEGUARD EDGE	SINGLE-TIER 7-1/2" HIGH	

Convex design provides extra work space for three operators. Comes complete with six pivot/tilt monitor mounts.



30172



30175



30178

B3053



B3055



30031

PIVOT/TILT MONITOR MOUNT

MODEL#	MOUNTING PATTERN COMPATIBILITY	WEIGHT
30172	75 x 75mm & 100 x 100mm	4 LBS.

Monitor mount features adjustable tension at pivot points for customized control, suitable for touchscreen use. Designed for 10" - 30" monitors and has a weight capacity of 40 pounds. For use on vertical or sloped Slat-Wall. Silver finish.

ARTICULATING PIVOT/TILT MONITOR MOUNT

MODEL#	DESCRIPTION	WEIGHT
30175	Articulating arm monitor mount	8 LBS.

Articulating arm monitor mount features adjustable tension at pivot points for customized control suitable for touchscreen use. Designed for 10" - 30" monitors and is compatible with 75 x 75mm and 100 x 100mm VESA mounting patterns. 30175 has a weight capacity of 40 pounds. Arm extends 17.2 inches. For use on vertical Slat-Wall only. Silver finish.

HEIGHT-ADJUSTABLE PIVOT/TILT MONITOR MOUNTS

MODEL#	DESCRIPTION	WEIGHT
30178	Articulating arm monitor mount - Vertical Slat-Wall	10 LBS.
B3053	Articulating arm monitor mount - Sloped Slat-Wall	11 LBS.

Articulating arm monitor mount features adjustable tension at pivot points for customized control suitable for touchscreen use. Designed for 10" - 30" monitors and is compatible with 75 x 75mm and 100 x 100mm VESA mounting patterns. 30178 has a weight capacity of 5-25 pounds. Arm extends 20.08" and features 13" of dynamic height adjustment using smooth-motion gas spring technology. Silver finish.

UNIVERSAL LARGE MONITOR MOUNT

MODEL#	OVERALL DIMENSIONS	COLOR	WEIGHT
B3055	16-1/2"H x 30-3/4"W x 2"D (419 x 781 x 51mm)	BLACK	14 LBS.

Heavy-Duty construction provides a low-profile mounting solution for 32"-52" monitors. Mount allows 0-12° of tilt and has a weight capacity of 125 pounds.

4U ENVISION RACK MOUNT CABINET

MODEL#	DIMENSIONS	WEIGHT
30031	9-1/8"H x 21-1/16"W x 6"D (232 x 535 x 152mm)	5 LBS.

4U rack cabinet easily mounts to the sloped or vertical Slat-Wall tiers providing convenient access to rack mounted equipment. Black textured powder coat finish.

POWER OUTLET WITH CIRCUIT BREAKER

MODEL#	DESCRIPTION	AMP	Outlet Length	WEIGHT
30701	Six-outlet	15	12-1/4" (311mm)	3 LBS.

Lighted On/Off switch. Mounts inside rear lift-off cable tray. Features a 15 foot cord.



REAR ACCESSORY TRAY FOR SLOPED SLAT-WALL

MODEL#	DESCRIPTION	WEIGHT
30080	EnVision accessory tray	4 LBS.

This convenient accessory tray mounts to the rear of the sloped EnVision Slat-Wall. The surface is 16" wide by 8" deep and has a 20 pound weight capacity. Black textured powder coat finish.



CONTEMPORARY LED TASK LIGHT

MODEL#	DESCRIPTION	WEIGHT
W5665	LED task light for vertical Slat-Wall	4 LBS.
B3056	LED task light for sloped Slat-Wall	4 LBS.

Optional Task Light features a three-bar design for ultimate reach and flexibility. The ultra-adjustable LED head can spin in its socket, sweep side to side, and rotate around the end of the arm to point in any direction. Dimming is easily controlled by a touchstrip located near the LED head for easy access.



ENVISION PENCIL DRAWER

MODEL#	DIMENSIONS	WEIGHT
B3099	2-3/8"H x 13-3/4"W x 18"D (60 x 349 x 457mm)	4 LBS.

Mounts to the underside of any EnVision work surface. Pulls out 12-3/4" (324mm). Black formed plastic.



PULLOUT, SWIVEL CPU MOUNT

MODEL#	DESCRIPTION	WEIGHT
B3098	Extends forward with 90° swivel	15 LBS.

Fits CPUs from 13-1/2" to 21-1/2" High (343 to 546mm) by 5-3/8" to 9-3/8" Wide (137 to 238mm). Black finish.





E-SOC CONTROL STATION

Winsted's innovative E-SOC Control Station is the perfect balance between our award-winning Prestige Console and our Multimedia Workstations. E-SOC features the Versa-Trak monitor mounting system for ergonomic comfort and adjustability. Lift-off access panels, integrated cable management and a hinged corner make E-SOC a flexible and feature-rich solution suitable for any application.

PRODUCT FEATURES AND HIGHLIGHTS

Endurance Plus Work Surface

E-SOC comes standard with our proprietary Endurance Plus Work Surface. Comfort Edge, Corian® and Marmoleum® work surface options are also available.

Versa-Trak Monitor Mounting System

Integrated horizontal aluminum track system will support a wide variety of monitor arrays. Versa-Trak offers the ultimate in versatility with easy horizontal adjustment. Post-mounted VESA brackets provide vertical adjustability along with the ability to tilt and pivot the monitors.

Rack Mount Turret

Optional 10-1/2" (6U) 7 degree sloped rack mount turret easily mounts to the E-SOC chase to keep electronics within easy reach. Features a vented top to keep electronics cool. Black textured power-coat finish.

Adjustable Monitor Mounts

VESA-compliant pivot/tilt mounts easily attach monitors to a support post, and provides smooth pivot and pitch adjustment for optimal viewing of flat panel monitors.

Vented Modesty Panel

Decorative, vented modesty panel features convenient lift-off panels for easy access to cables, electronics and CPUs. Integrated cable management with lacing loops enhances the feature set of the E-SOC.

Rack Mount Cabinet

Winsted offers a 19" EIA Rack Mount Cabinet to compliment your Control Station. A wide range of shelves and accessories are available to build the perfect rack solution.

Easy-Access Cable Management

Enhance reliability while protecting and managing your cables. All E-SOC Control Stations feature a cable channel with lacing loops incorporated into the modesty panel and a large, drop-down hinged cable tray that spans the length of the modesty panel.

Three Monitor Mount Post Heights

Available in three different heights: 15", 28-1/2", and 42" so you can create a monitor array suitable for any application.

CPU Mount

CPU mount provides easy access to the front and rear of your computer system. The articulating mount extends forward, includes a 90° swivel, and fits CPUs from 13-1/2" to 21-1/2"H by 5-3/8" to 9-3/8"W.

Optional Task Light

Optional Task Light features a three-bar design for ultimate reach and flexibility. The ultra-adjustable LED head can spin in its socket, sweep side to side, and rotate around the end of the arm to point in any direction. A brightness touchstrip is located near the LED head for easy access.

Powder-Coat Paint

The E-SOC infrastructure is coated with a durable black powder-coat paint that accentuates the work surface. Textured finish prevents fingerprints from showing and lasts for years.

Hinged Corner

E-SOC's innovative hinged corner offers the ultimate in flexibility. With no pre-defined corner angles, E-SOC can be designed to fit in your unique space.

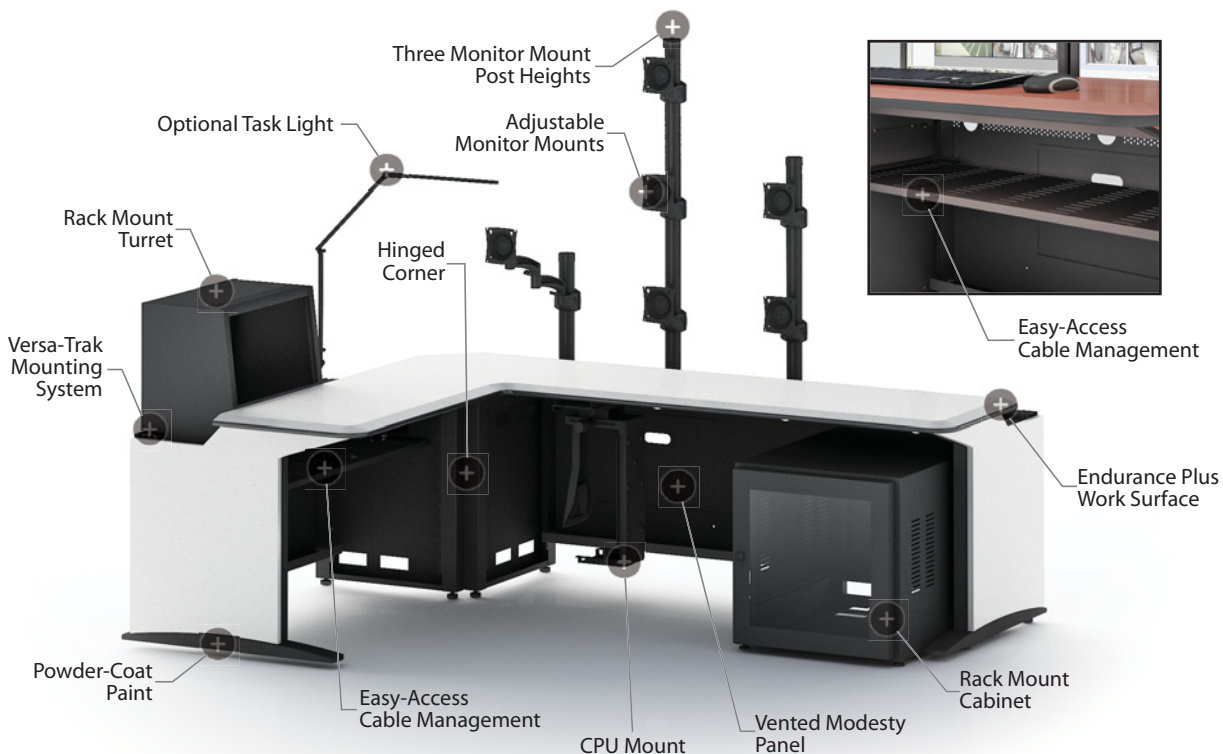

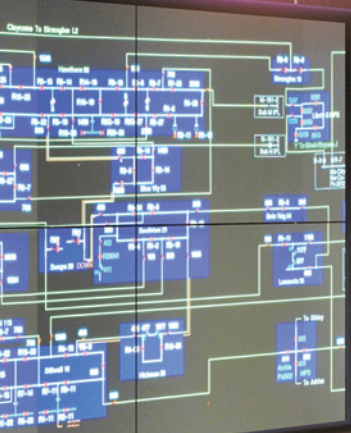

E-SOC

CONTROL STATION

CONTROL ROOM FUSION

Ergonomic improvements result in greater comfort and improve the performance of operators monitoring complex systems. E-SOC combines a comprehensive set of features to keep your operators aware of what's going on at all times. Part workstation and part console, E-SOC Control Station is a ground-breaking fusion of our workstations and our award winning consoles. E-SOC offers the flexibility, the feature set and the price point to suit any control room installation small or large.

FEATURES

- Modular and Expandable
- Ergonomically Correct
- Improved Operator Performance
- Robust Feature Set
- Infinite Corner Configurations





48" E-SOC CONTROL STATION

MODEL#	HEIGHT	WIDTH	DEPTH
B4312	28-7/8" (733mm)	48" (1219mm)	28-7/8" (733mm)
BASE COLOR	SIDE PANEL	WORK SURFACE	
BLACK	CONCRETE TRUFORM	CONCRETE ENDURANCE PLUS	

48" wide E-SOC Control Station features the Versa-Trak monitor mounting system and comes complete with two W6491 articulating monitor mounts (See page 43). To order this Control Station without the monitor mounts, please use model number B4302.

60" E-SOC CONTROL STATION

MODEL#	HEIGHT	WIDTH	DEPTH
B4314	28-7/8" (733mm)	60" (1524mm)	28-7/8" (733mm)
BASE COLOR	SIDE PANEL	WORK SURFACE	
BLACK	CONCRETE TRUFORM	CONCRETE ENDURANCE PLUS	

60" wide E-SOC Control Station features the Versa-Trak monitor mounting system and comes complete with three W6491 articulating monitor mounts (See page 43). To order this Control Station without the monitor mounts, please use model number B4304.



72" E-SOC CONTROL STATION

MODEL#	HEIGHT	WIDTH	DEPTH
B4316	28-7/8" (733mm)	72" (1829mm)	28-7/8" (733mm)
BASE COLOR	SIDE PANEL	WORK SURFACE	
BLACK	CONCRETE TRUFORM	CONCRETE ENDURANCE PLUS	

72" wide E-SOC Control Station features the Versa-Trak monitor mounting system and comes complete with four W6491 articulating monitor mounts (See page 43). To order this Control Station without the monitor mounts, please use model number B4306.

60" E-SOC CONTROL STATION WITH RACK

MODEL#	HEIGHT	WIDTH	DEPTH
B4324	28-7/8" (733mm)	60" (1524mm)	28-7/8" (733mm)
BASE COLOR	SIDE PANEL	WORK SURFACE	
BLACK	CONCRETE TRUFORM	CONCRETE ENDURANCE PLUS	

60" wide E-SOC Control Station with 19-1/4" (11U) equipment rack features the Versa-Trak monitor mounting system and comes complete with three W6491 articulating monitor mounts (See page 43).



U-SHAPED E-SOC CONTROL STATION

MODEL#	HEIGHT	WIDTH	DEPTH
B4353	28-7/8" (733mm)	113-1/8" (2873mm)	78-7/16" (1992mm)
BASE COLOR	SIDE PANEL	WORK SURFACE	
BLACK	AMERICAN NATURAL TRUFORM	EUCALYPTUS MARMOLEUM	

This U-shaped Control Station consists of two 60" sections, one 72" section and two 90 degree corners. Comes complete with Versa-Trak monitor mounting system and ten W6491 articulating monitor mounts (See page 43).



CORNER E-SOC CONTROL STATION

MODEL#	HEIGHT	WIDTH	DEPTH
B4350	28-7/8" (733mm)	140-1/4" (3562mm)	60-1/2" (1537mm)
BASE COLOR	SIDE PANEL	WORK SURFACE	
BLACK	SHARK GREY TRUFORM	LAVA MARMOLEUM	

This Corner Control Station consists of three 48" sections and two 45 degree corners. Comes complete with Versa-Trak monitor mounting system and six W6471 pivot/tilt monitor mounts (See page 43).



L-SHAPED E-SOC CONTROL STATION

MODEL#	HEIGHT	WIDTH	DEPTH
B4351	28-7/8" (733mm)	92-3/16" (2342mm)	92-3/16" (2342mm)
BASE COLOR	SIDE PANEL	WORK SURFACE	
BLACK	BOSTON CHERRY TRUFORM	RUST MARMOLEUM	

This L-shaped Control Station consists of two 72" sections and one 90 degree corner. Comes complete with Versa-Trak monitor mounting system and six W6491 articulating monitor mounts (See page 43).



CURVED E-SOC CONTROL STATION

MODEL#	HEIGHT	WIDTH	DEPTH
B4352	28-7/8" (733mm)	234-11/16" (5961mm)	54-3/4" (1391mm)
BASE COLOR	SIDE PANEL	WORK SURFACE	
BLACK	SHARK GREY TRUFORM	COBALT OXIDE MARMOLEUM	

This Curved Control Station consists of five 48" sections and four 10 degree corners. Comes complete with Versa-Trak monitor mounting system and ten W6471 pivot/tilt monitor mounts (See page 43).



WELDED 19-1/4" (11U) RACK WITH PLEXI DOOR

MODEL#	DIMENSIONS	WEIGHT
43009	22-7/16"H x 22"W x 28"D (570 x 559 x 711mm)	44 LBS.

Welded 19-1/4" (11U) equipment rack comes complete with front and rear tapped rack rails, removable back panel, leg levelers and plexiglas front door. Side panels are vented and the removable back panel allows for two 1-3/4" openings at the top and bottom for cooling and cabling.

STATIONARY CPU MOUNT

MODEL#	DESCRIPTION	WEIGHT
43260	Extends forward with 90° swivel	8 LBS.

Fits CPU's from 13-1/2" to 21-1/2" High (343 to 546mm) by 5-3/8" to 9-3/8" Wide (137 to 238mm). Black finish.

RACK MOUNT TURRET

MODEL#	DIMENSIONS	WEIGHT
43032	16-1/16"H x 21-3/16"W x 12-7/8"D (410 x 538 x 327mm)	18 LBS.

10-1/2" (6U) 7° sloped rack mount turret easily mounts to the E-SOC chase to keep electronics within easy reach. Features a vented top to keep electronics cool. Black textured power-coat finish.

13-3/4" WIDE PENCIL DRAWER - BLACK

MODEL#	DIMENSIONS	WEIGHT
55233	2-3/8"H x 13-3/4"W x 18"D (60 x 349 x 457mm)	4 LBS.

Mounts to the under-side of any work shelf. This drawer fits between console shelf brackets. Pulls out 12-3/4" (324mm). Black formed plastic.

LED TASK LIGHTS

MODEL#	DESCRIPTION	WEIGHT
W5664	Versa-Trak mounted task light	4 LBS.

Optional Task Light features a three-bar design for ultimate reach and flexibility. The ultra-adjustable LED head can spin in its socket, sweep side to side, and rotate around the end of the arm to point in any direction. Dimming is easily controlled by a touchstrip located near the LED head for easy access.

56679	LED light with magnetic base and 18" flexible neck	1 LB.
10679	LED light with VESA mount and 18" flexible neck	1 LB.

Features a 6-foot cord and allows users to switch between white or red lights.

AXIOM MONITOR MOUNTS: (1.5" DIA. MOUNTING POSTS)

W6471

15" Post - Single Monitor Post Mount, Vertical



W6472

28-1/2" Post - Dual Monitor Post Mount, Vertical



W6473

42" Post - Triple Monitor Post Mount, Vertical



W6491

15" Post - Single Monitor Articulating Arm



W6492

28-1/2" Post - Single Monitor Articulating Arm



W6493

28-1/2" Post - Dual Monitor Two Articulating Arms



W6496

15" Post - Dual Monitor Mount Dual Articulating Arms



W6497

28" Post - Quad Monitor Mount Two Dual Articulating Arms



W6469

Adjustable Phone Tray Mounts to Versa-Trak



PRESTIGE MONITOR MOUNTS: (1.9" DIA. MOUNTING POSTS)

E5081

15" Post - Single Monitor Post Mount, Vertical



W5772

28-1/2" Post - Dual Monitor Post Mount, Vertical



W5773

42" Post - Triple Monitor Post Mount, Vertical



W5777

15" Post with Dual 15" Extension Arms



W5690

Dual-Post Large Monitor Mount (Supports 42" - 63" Monitors)



W5774

15" Post with 15" Extension Arm



W5775

28-1/2" Post with 15" Extension Arm



W5776

42" Post with Two 15" Extension Arms



W5778

15" Post with Height Adjustable Arm



W5698

28-1/2" Post with VESA Mount (Supports 26" - 45" Displays)





Winsted
Control Room Consoles

M-VIEW MONITOR WALLS

Winsted's M-View monitor wall, in-stock or custom built, is flexible in design and completely modular. M-View is fabricated from light-weight, high strength extruded aluminum with a black anodized finish. The monitor wall can support virtually any monitor configuration and can be designed as an in-line, concave or convex mounting solution. The M-View seamlessly integrates technology and space to optimize viewing angles.

PRODUCT FEATURES AND HIGHLIGHTS

Stock and Custom Monitor Walls

Choose an in-stock monitor wall that is preconfigured and ready to ship or let Winsted design a custom monitor wall built to your specific monitor configuration.

Large Flat Panel Mounts

Our heavy-duty large LCD/plasma mounts combine a low profile design with integrated security features. The mount features a rapid leveling system, quick connect disconnect installation, fingertip-tilt, and a pullout bottom for convenient cable access. Allows for portrait or landscape flat panel installation.

Standard VESA Mounts

Universal VESA mounts easily attach flat panel monitors to the M-View Monitor Wall and provide smooth pivot and pitch adjustment for different viewing angles and ergonomic needs. The VESA mounts move freely along the M-View framework and are available to support almost any monitor.

1-1/2" x 3" Exterior Frame

The exterior framing is constructed of 1-1/2" x 3" extruded aluminum for superior strength and modularity. Custom frames can be manufactured to any height and length.

Power Strips

Ten, eleven, or twenty outlet power strips are available with on/off switches and circuit breakers. Power strips mount to the rear of the horizontal and/or vertical frame sections.

Black Anodized Finish

All M-View frames feature a black anodized finish that fits seamlessly into any environment. When installed, the M-View frame blends in with attached monitors, creating a pleasing shadow effect. Clear and custom anodized colors are available.

1-1/2" x 1-1/2" Interior Supports

The interior supports are constructed of extruded aluminum for superior strength and modularity. Custom frames can be manufactured to any height and length.

Cable and Wire Management

Multiple raceway channels are available for wire management. Run the cables horizontally or vertically using model M1032 (scored walls). Use model M1030 (solid walls) to run cables vertically to the floor.

Modular and Expandable

All M-View monitor walls are designed to support your monitor configuration. The M-View can be expanded and reconfigured based on your changing needs.

Optional Filler Panel

Complete your M-View with custom filler panels, available in a variety of colors and materials. Can be cut to provide access to electronics or vertical rack.

Quick-Release Adjustable Bracket

Our NEW quick-release bracket makes adjusting and reconfiguring your monitors fast and easy on our stock monitor walls.

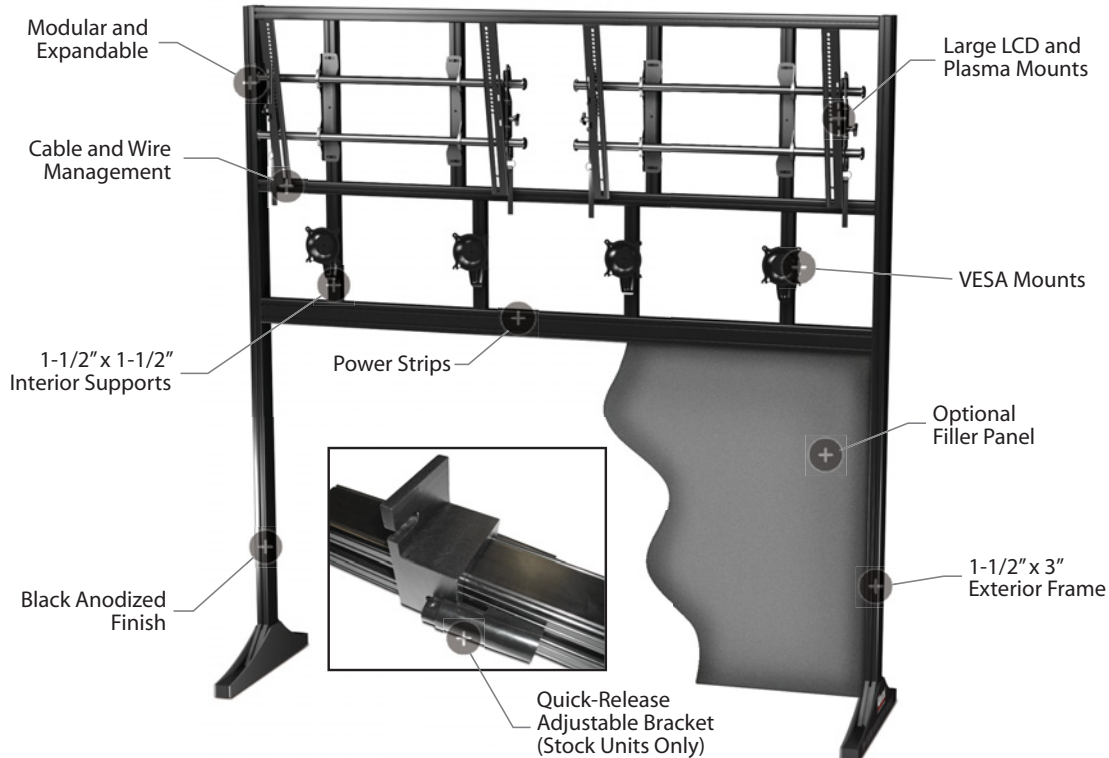



M-VIEW

MONITOR WALLS

CUSTOM MONITOR WALLS

If you require a custom-built monitor wall to support your specific monitor configuration, or to fit in your unique space, please contact Winsted and we will provide the perfect solution. Each custom M-View is designed and manufactured from the ground up to meet your specifications. The M-View is fabricated from light-weight, high-strength extruded aluminum and will support any size flat-panel monitor.

FEATURES

- Stock and Custom Walls Available
- Light Weight and High Strength
- Easy to Wire and Maintain
- Adapts to Changing Technology
- Prevents Damage to Interior Walls



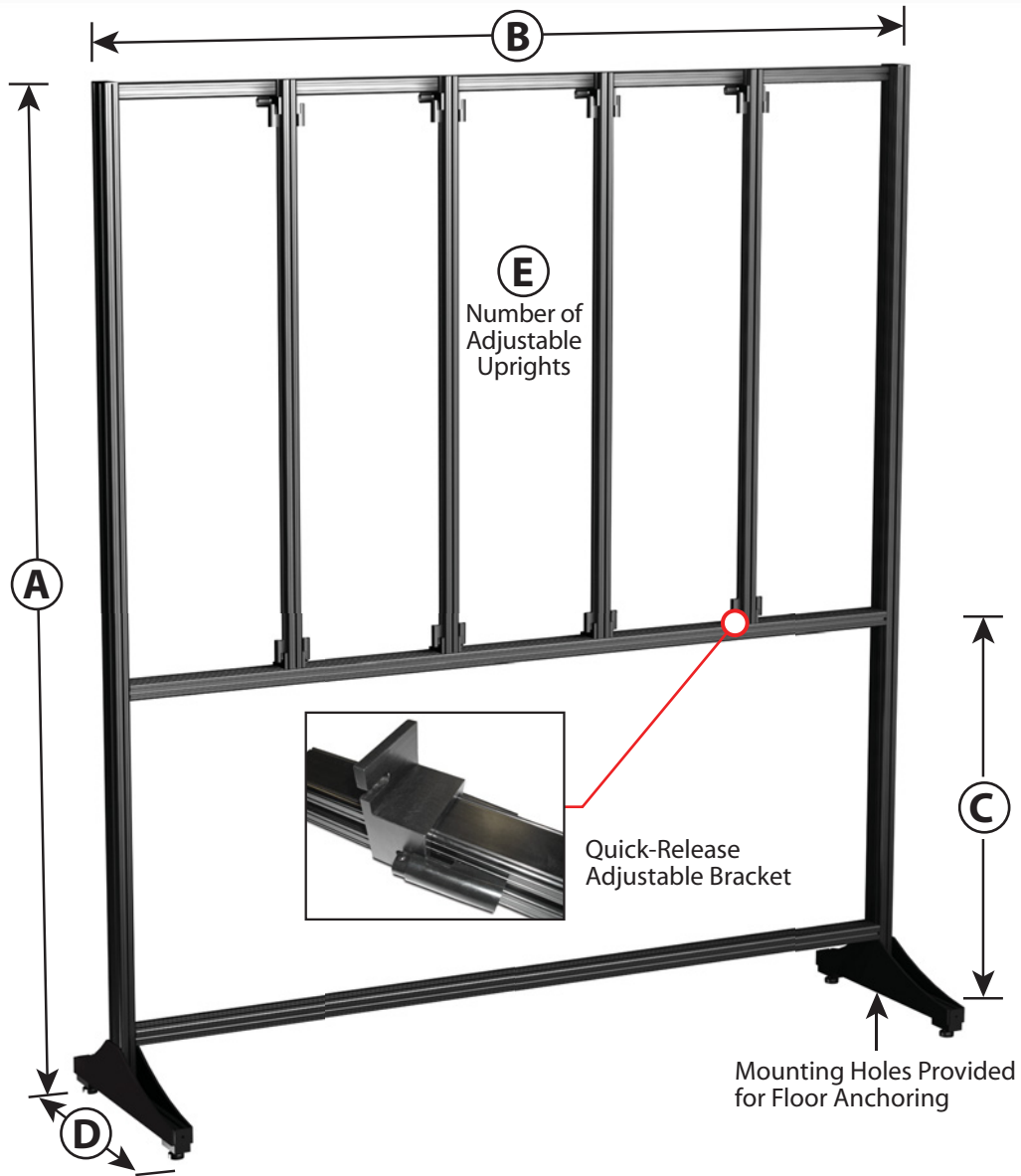

STOCK FRAMES WITH ADJUSTABLE UPRIGHTS

MODEL#	A	B	C	D	E	COLOR	WEIGHT
M1100	80" (2032mm)	43" (1092mm)	24-1/2" (622mm)	24" (610mm)	2	BLACK	91 LBS.
M1102	80" (2032mm)	53" (1346mm)	24-1/2" (622mm)	24" (610mm)	2	BLACK	93 LBS.
M1104	80" (2032mm)	63" (1600mm)	24-1/2" (622mm)	24" (610mm)	3	BLACK	98 LBS.
M1106	80" (2032mm)	73" (1854mm)	24-1/2" (622mm)	24" (610mm)	4	BLACK	103 LBS.
M1108	80" (2032mm)	83" (2108mm)	24-1/2" (622mm)	24" (610mm)	4	BLACK	105 LBS.
M1121	94" (2388mm)	43" (1092mm)	38-1/2" (978mm)	24" (610mm)	2	BLACK	96 LBS.
M1123	94" (2388mm)	53" (1346mm)	38-1/2" (978mm)	24" (610mm)	2	BLACK	98 LBS.
M1125	94" (2388mm)	63" (1600mm)	38-1/2" (978mm)	24" (610mm)	3	BLACK	103 LBS.
M1127	94" (2388mm)	73" (1854mm)	38-1/2" (978mm)	24" (610mm)	4	BLACK	108 LBS.
M1129	94" (2388mm)	83" (2108mm)	38-1/2" (978mm)	24" (610mm)	4	BLACK	110 LBS.

Stock frames are pre-configured and ready to ship. All stock frames feature our NEW quick-release adjustable bracket.

VESA MOUNTS

MODEL#	DESCRIPTION	VESA MOUNT	WEIGHT CAPACITY	WEIGHT
51237	LCD Mount 10"-32" Monitor	75 x 75mm 100 x 100mm	40 LBS.	3 LBS.
51239	LCD Mount 26"-45" Monitor	100 x 100mm 100 x 200mm 200 x 200mm	75 LBS.	5 LBS.

VESA monitor mounts allow smooth range of motion and hassle free, fingertip positioning of the monitors. Low profile appearance and sleek, attractive design conceals all hardware.



UNIVERSAL LARGE LCD/PLASMA MOUNT

MODEL#	OVERALL DIMENSIONS	COLOR	WEIGHT
11104	13.2"H x 34.44"W x 1.99"D (335 x 875 x 51 mm)	BLACK	19 LBS.

Heavy-Duty construction provides a secure mounting solution for monitors up to 63" wide and/or 200 pounds.



POWER SUPPLY OUTLETS WITH CIRCUIT BREAKERS

MODEL#	DESCRIPTION	AMP	Outlet Length	WEIGHT
M1020	Ten-outlet	15	34" (864mm)	4 LBS.
M1021	Ten-outlet	15	68" (1727mm)	6 LBS.
M1022	Twenty-outlet	15	68" (1727mm)	7 LBS.
M1023	Eleven-outlet	20	68" (1727mm)	8 LBS.

On/Off switch. Mounts to any vertical or horizontal frame section where power is needed.



PANEL CHANNEL WIRE MANAGEMENT DUCTS

MODEL#	OVERALL DIMENSIONS	COLOR	WEIGHT
M1030	1-1/2"H x 1-1/2"W x 72"L (38 x 38 x 1829mm)	BLACK	2 LBS.
M1032	2"H x 2"W x 78"L (51 x 51 x 1981mm)	BLACK	2 LBS.
M1034	2"H x 4"W x 78"L (51 x 102 x 1981mm)	BLACK	3 LBS.

Black plastic channel with scored sidewalls for easy breakout. Protective channel can be cut to size. Model M1030 has solid walls. Covers included.



M1030



M1032



PRO-SERIES II VERTICAL RACKS

All vertical racks are performance designed to deliver the features and functions for any installation. All racks are backed by a lifetime warranty. Vertical Racks are available in multiple styles and sizes to meet your rack mount equipment needs. Flexible delivery choices, thermal management, and a wide range of optional accessories allow you to customize your solution to your exact requirements.

PRODUCT FEATURES AND HIGHLIGHTS

Top Panel Options

Individual racks include a variety of top options: raised vented panels, solid and vented blank panels and internal/external mounted fans. Full or partial top coverage provides flexible ceiling cabling options.

Welded Frames

Racks utilize extra-heavy-duty welded construction delivering robust solutions in the most demanding environments.

Lacing Bars

A variety of vertical and horizontal lacing bars are available for each rack style, including a 71" solid copper bus bar.

Adjustable Tapped Rack Rails

Adjustable front and rear 14-gauge tapped rack rails for equipment installation. Rails are stamped with numbered rack increments.

NEMA Conduit Knock-outs

Pro Series II rack frames include NEMA - approved knock-outs which provide excellent wire management with multiple conduit sizes.

Pedestal Wire Access Holes

Rack frame includes two 4" x 10" openings in the pedestal for air intake and cable management.

Powder-Coat Finish

The heavy-duty steel infrastructure of each rack is coated with a durable black powder-coat paint. Textured paint provides a beautiful finish in all environments.

Vented Side Panels

Removable half-height side panels are standard. Convection-cooling side panel venting can be covered when vertical thermal management fans are used.





PRO SERIES II WELDED VERTICAL RACKS

24"D (610mm) RACK CABINET

MODEL#	RACK HEIGHT	OVERALL HEIGHT	WEIGHT
90012	35" (20U)	42" (1067mm)	66 LBS.
90016	70" (40U)	77" (1956mm)	105 LBS.
90018	78-3/4" (45U)	85" (2159mm)	110 LBS.

21-3/4"D from front rack rail to rear rack rail.

32"D (813mm) RACK CABINET

90022	35" (20U)	42" (1067mm)	75 LBS.
90026	70" (40U)	77" (1956mm)	115 LBS.
90028	78-3/4" (45U)	85" (2159mm)	125 LBS.

29-3/4"D from front rack rail to rear rack rail.

38-3/8"D (975mm) RACK CABINET

90032	35" (20U)	42" (1067mm)	110 LBS.
90036	70" (40U)	77" (1956mm)	139 LBS.
90038	78-3/4" (45U)	85" (2159mm)	140 LBS.

36"D from front rack rail to rear rack rail.

DVR RACK - BLACK

MODEL#	DESCRIPTION	WEIGHT
V9019	78-3/4"H (45U) x 38-3/8"D vertical rack with vented side panels, locking rear solid door, vented top panel panel & 5-1/4"H (3U) 300 CFM rack mount filtered fan.	290 LBS.

Whether you are populating a single vertical rack with DVRs or have an entire room to fill, the Pro Series II DVRack is perfect for this application. Order one model number for a complete single rack.

V9021	78-3/4"H (45U) x 38-3/8"D vertical rack with locking side panels, locking rear solid door, vented top panel & 5-1/4"H (3U) 300 CFM rack mount filtered fan.	188 LBS.
-------	---	----------

Filling a room? Order multiple racks frames without side panels to create in-line bays.

VENTED SIDE PANELS - BLACK (PAIRS)

24"D (610mm) RACK CABINET

MODEL#	RACK HEIGHT (UNITS)	WEIGHT
90112	35" (889mm) (20U)	33 LBS.
90116	70" (1778mm) (40U)	60 LBS.
90118	78-3/4" (2000mm) (45U)	62 LBS.

32"D (813mm) RACK CABINET

90122	35" (889mm) (20U)	42 LBS.
90126	70" (1778mm) (40U)	74 LBS.
90129	78-3/4" (2000mm) (45U)	86 LBS.

38-3/8"D (975mm) RACK CABINET

90132	35" (889mm) (20U)	53 LBS.
90136	70" (1778mm) (40U)	90 LBS.
90138	78-3/4" (2000mm) (45U)	104 LBS.

Side panels provide ample venting for convection cooling.

VENTED TOP PANELS - BLACK

MODEL#	RACK CABINET DEPTH	WEIGHT
90051	24" (610mm)	8 LBS.
90053	32" (813mm)	11 LBS.
90055	38-3/8" (975mm)	13 LBS.

Includes bracket for Model 10705 exhaust fan. (Fan sold separately - Page 61)

SOLID BLANK TOP PANELS - BLACK (19" W)

MODEL#	RACK SIZE	PANEL SIZE	WEIGHT
99145	24"D	19"W (483) x 10-1/2"H (6U)	4 LBS.
99148	32"D	19"W (483) x 19-1/4"H (11U)	8 LBS.
99152	38-3/8"D	19"W (483) x 24-1/2"H (14U)	11 LBS.

Solid top panels easily mount in the standard 19" vertical rack top.

VENTED BLANK TOP PANELS - BLACK (19" W)

MODEL#	RACK SIZE	PANEL SIZE	WEIGHT
86142 (2)	24"D	19"W (483) x 5-1/4"H (3U)	2 LBS.
86149	32"D	19"W (483) x 19-1/4"H (11U)	4 LBS.
86142 (1)	38-3/8"D	19"W (483) x 5-1/4"H (3U)	1 LB.
86149 (1)	38-3/8"D	19"W (483) x 19-1/4"H (11U)	4 LBS.

Vented beehive panels reduce heat build-up.

TAPPED OUTER RACK RAIL - PAIRS

MODEL#	RACK CABINET DEPTH	WEIGHT
90262	35" (20U)	4 LBS.
90266	70" (40U)	8 LBS.
90269	78-3/4" (45U)	9 LBS.

Right and left rails sold as pairs. 12-Gauge steel with numbered rack units and black zinc plating. Order 10-32 mounting screws separately. Model 10800 (Silver) or 10814 (Black). 50 each per pack.

SCREWS AND WASHERS

MODEL#	DESCRIPTION	WEIGHT
10800	10-32 x 3/4" Silver Pilot screws and washers. 50 each.	0.5 LB.
10814	10-32 x 3/4" Black Pilot screws and washers. 50 each.	0.5 LB.

Pilot screws make it easy to install your electronics.

2-1/2" (64MM) PLATE CASTERS - SET OF FOUR

MODEL#	DESCRIPTION	WEIGHT
85782	For 24"D, 32"D & 38-3/8"D rack cabinets (mount to pedestal only)	4 LBS.

Heavy duty casters allow you to move your vertical rack with ease.

LEG LEVELERS & GUSSETS — SET OF FOUR

MODEL#	HEIGHT	WEIGHT
90270	For 24"D, 32"D & 38-3/8"D rack cabinets	1 LB.

Mounts to rack bottom or pedestals.

STANDARD BLACK PEDESTAL - 22-1/8"W

MODEL#	DIMENSIONS	WEIGHT
90072	24"D x 2-1/2"H (610 x 64mm)	15 LBS.
90076	32"D x 2-1/2"H (813 x 64mm)	16 LBS.
90078	38-3/8"D x 2-1/2"H (975 x 64mm)	18 LBS.

Pedestals provide conduit knock-outs and removable side sections for horizontal cable management.

10" COOLING FAN - BLACK



MODEL#	FAN MEASURES	CFM	WEIGHT
G9085	3-1/2"H x 10"W (89 x 254mm)	550	9 LBS.

Comes complete with 5 foot cord, two finger guards and a 10-1/2" (6U) blank panel for mounting in the Pro Series II vertical rack top.

PRO SERIES II LOCKING DOORS

Rack Frame Size	35" (20U) Mounts to the front/rear frame of Models 90012, 90022, 90032	70" (40U) Mounts to the front/rear frame of Models 90016, 90026, 90036	78-3/8" (45U) Mounts to the front/rear frame of Models 90018, 90028, 90038			
DESCRIPTION	MODEL#	WEIGHT	MODEL#	WEIGHT	MODEL#	WEIGHT
PLEXIGLASS	90332 Front Only	18 LBS.	90336 Front Only	31 LBS.	90338 Front Only	37 LBS.
VENTED SOLID	90322 Front Only	16 LBS.	90326 Front Only	31 LBS.	90328 Front Only	34 LBS.
SOLID	90312 Rear Only	12 LBS.	90316 Rear Only	24 LBS.	90318 Rear Only	26 LBS.

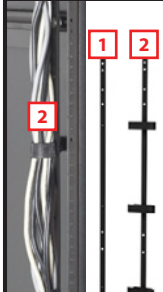

All doors can be installed to open from left or right. Black texture powder coat finish.

VERTICAL RACK LACING OPTIONS - BLACK

	MODEL#	DESCRIPTION	WEIGHT
	1 88217	71-3/4" Lacing strip, supplies multiple binding locations. Fits models 90018, 90028, 90038	2 LBS.
	2 88218	Eight 14" long Velcro straps, mounted on a pre-drilled 72"H x 3/4"W x 1/8" Thick metal strap	2 LBS.
	3 88226	71" Copper bus bar. 1/4" thick x 1"W strap. Fits models 90018, 90028 and 90038. (Not Shown)	6 LBS.

Enhance reliability while protecting and managing your cables.

HORIZONTAL RACK LACING OPTIONS - BLACK

	MODEL#	DESCRIPTION	WEIGHT
	5 90273	1/2"H Black rack mount slotted lacing strip with horizontal slots	0.5 LB.
	6 10220	1-3/4" Slotted lacing rack mount panel with horizontal slots	1 LB.
	7 85276	Aluminum round bar rack mount cable guide extends cable life	0.5 LB.

All horizontal lacing options mount in any standard 19" opening.

UNIVERSAL RACK MOUNT SHELVES - BLACK

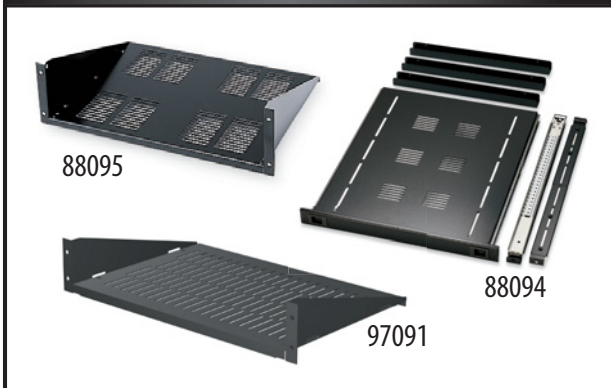

MODEL#	DESCRIPTION	WEIGHT
88091	3-1/2" (2U) Stationary shelf. 2-7/8"H x 18"D (73 x 457mm)	8 LBS.
88093	5-1/4" (3U) Stationary shelf. 4-5/8"H x 18"D (117 x 457mm)	9 LBS.
88095	8-3/4" (5U) Stationary shelf. 8-1/8"H x 18"D (206 x 457mm)	10 LBS.
88096	10-1/2" (6U) Stationary shelf. 9-7/8"H x 18"D (251 x 457mm)	11 LBS.
97091	3-1/2" (2U) Stationary shelf. 2-7/8"H x 12"D (73 x 305mm) Includes Strap Model 12765 for securing electronics	6 LBS.
88094	20" (508mm) Extension pullout shelf. Locks in closed position. Uses 1-3/4" (1U) rack space	17 LBS.

Fits into any 19" EIA (482mm) rack. Heavy 14 gauge sides, 16 gauge bottom, and 12" or 18" deep vented bottom for cooling and strapping down electronics.

UNIVERSAL SHELF SUPPORT BRACKETS - BLACK



MODEL#	SIZE	WEIGHT
88220	Brackets support up to a 24"D work surface	9 LBS.

Fastens to front and rear rack rails of any standard 19" EIA cabinet ranging from 22" to 36" D (559 to 914mm).

PRO SERIES I & II TRUFORM WORK SURFACES - 18"D

	MODEL#	DESCRIPTION	WIDTH	WEIGHT
	90661	Single-Bay	22-1/8"	29 LBS.
	90662	Two-Bay	44-1/4"	50 LBS.
	90663	Three-Bay	66-3/8"	75 LBS.
	90664	Four-Bay	88-1/2"	96 LBS.

18"D (457mm) work surface with a 1-3/4" (44mm) beveled front edge. Black TruForm finish.

BLANK PANEL FILLER KITS

KIT #1			KIT #2			KIT #3		
MODEL#	QTY.	WT.	MODEL#	QTY.	WT.	MODEL#	QTY.	WT.
G9101	4ea. (1U) 2ea. (2U) 1ea. (3U)	9 LBS.	G9102	4ea. (1U) 2ea. (2U) 1ea. (9U)	14 LBS.	G9103	4ea. (1U) 2ea. (2U) 1ea. (11U)	16 LBS.

All blank panel kits include mounting hardware (50 bolts and clips).

SQUARE HOLE RACK RAILS - BLACK

	MODEL#	HEIGHT	WEIGHT
	90267	70"	3 LBS.
	90271	78-3/4"	3 LBS.
	G8060	Square Tinnerman Nut 25 Each	1 LB.

Designed to mount in Pro Series II vertical racks.

UTILITY DRAWERS WITH LOCK - BLACK



MODEL#	SIZE	WEIGHT
88321	8-3/4" (5U) rack mountable pullout utility drawer	18 LBS.
88324	12-1/4" (7U) rack mountable letter/legal size pullout file drawer	23 LBS.

All drawers feature heavy duty ball bearing slides for years of reliability.

RACK MOUNT KEYBOARD SHELF - BLACK

88397



MODEL#	DESCRIPTION	WEIGHT
88397	Holds keyboards up to 16-1/2"W (419mm)	14 LBS.
88398	Holds keyboards up to 21"W (533mm) Swivels 90° to fit in a rack	18 LBS.

Conveniently stores your keyboard inside the vertical rack.

MULTI-PURPOSE UTILITY DRAWER - BLACK



MODEL#	DESCRIPTION	WEIGHT
88323	3-1/2"H (2U) Utility Drawer	15 LBS.

Can be rack mounted or mounted to the underside of any wood work surface. 3-3/8" (86mm) inside height.

COOLING FAN - WITH 5' CORD & PLUG



MODEL#	VOLTS	DECIBELS	CFM	WEIGHT
10705	115	43	105	2 LBS.
10724	220	43	105	2 LBS.
10725	115	30	55	2 LBS.

Easily mounts to vented side panels or vented top panels.

19" WIDE EIA BLANK PANELS



MODEL# PEARL GREY	MODEL BLACK	HEIGHT	RACK UNIT	WEIGHT
85140	99140	1-3/4" (44mm)	(1U)	1 LB.
85141	99141	3-1/2" (89mm)	(2U)	1 LB.
85142	99142	5-1/4" (133mm)	(3U)	2 LBS.
85143	99143	7" (178mm)	(4U)	3 LBS.
85144	99144	8-3/4" (222mm)	(5U)	3 LBS.
85145	99145	10-1/2" (267mm)	(6U)	4 LBS.
85146	99146	12-1/4" (311mm)	(7U)	4 LBS.
85147	99147	14" (356mm)	(8U)	6 LBS.
85148	99148	15-3/4" (400mm)	(9U)	7 LBS.
85149	99149	19-1/4" (489mm)	(11U)	8 LBS.
85152	99152	24-1/2" (622mm)	(14U)	10 LBS.

Our 16 gauge steel blank panels are flanged for extra strength. They are finished attractively in textured powder coat paint. All sizes are available in Pearl Grey or Black. Just choose the appropriate size blank panel to provide the perfect finishing touch for all of your installations.

EXTRA DEEP VENTED STATIONARY SHELF - BLACK



MODEL#	DESCRIPTION	WEIGHT
88090	Rear supports adjust 22" to 37-3/4"D (559 x 956mm) to fit a wide variety of rack cabinets	11 LBS.

Inside tray dimensions: 17-3/8"W x 21-3/4"D (441 x 552mm). Requires just 3-1/2" (2U) of rack space. Overall dimensions: 3-1/2"H x 19"W x 21-3/4"D (89 x 483 x 552mm).

LAMINATED TABLE TOP RACKS - BLACK



MODEL#	DESCRIPTION	WEIGHT
99484	7"H (4U) Table Top Rack 8-1/4"H x 20-3/8"W x 18"D (210 x 518 x 457mm)	19 LBS.
99488	14"H (8U) Table Top Rack 15-1/4"H x 20-3/8"W x 18"D (387 x 518 x 457mm)	23 LBS.

Comes complete with laminated top, bottom, a pair of side panels and tapped zinc plated rack rails. Black finish.

METAL TABLE TOP RACKS - BLACK



MODEL#	DESCRIPTION	WEIGHT
V4211	21"H (12U) Table Top Rack 23-5/8"H x 21-9/16"W x 18-3/4"D (600 x 548 x 476mm)	36 LBS.
V4221	28"H (16U) Table Top Rack 30-5/8"H x 21-9/16"W x 18-3/4"D (778 x 548 x 476mm)	41 LBS.

Standard EIA 19"W cabinets. Two sides, top and bottom. Winsted's "High-Tech" table top rack design fits perfectly in the security market. Steel construction protected by a Black enamel finish. Vented sides to cool your electronics.



SPECTRUM CONSOLES

Winsted's Spectrum consoles offer flexible equipment mounting options, ergonomic viewing angles and easy expansion. Whether you're creating a single-bay edit suite for video production or a sophisticated multi-operator control room, Winsted offers the perfect rack mount console for your precise needs. Each of our rack mount consoles conforms to 19" W EIA standards and provides easy access to rack mounted electronics.

PRODUCT FEATURES AND HIGHLIGHTS

Multiple Work Surface Options

Choose from three work surface options. Our proprietary Marmoleum, Endurance Plus, and Comfort Edge options are available on all Spectrum consoles.

Base/Slope Sections

24-1/2" (14U) vertical base sections can be configured with a custom sloped upper section providing up to 15-3/4" (9U). Slope sections deliver an ergonomic viewing angle and easy equipment access. Base section is ideal for decks, CPUs and limited-access electronics.

Front Tapped Rack Rails

Upper and lower front 14-gauge tapped rack rails for equipment installation. Rails are stamped with numbered rack increments for easy equipment installation.

High Pressure Laminate Finish

Get the looks you want and the durability you need. All structural panels are constructed with high-pressure laminate bonded to 1" industrial grade particle board and finished with solid oak trim. Hundreds of laminate colors to choose from.

Grommet Holes

The work surface, top panels, and internal bottom panels all feature cable grommets for convenient and clean cable management.

Optional Versa-Trak Mounting System

Integrated horizontal aluminum track system will support a wide variety of monitor mounts. Versa-Trak offers the ultimate in versatility with easy horizontal adjustment. Post-mounted VESA brackets provide vertical adjustability along with the ability to tilt and pivot the monitors.

Optional Adjustable Monitor Mounts

VESA-compliant pivot/tilt articulating monitor mounts easily attach monitors to the Versa-Trak and provide smooth pivot and pitch adjustment for optimal viewing angles and ergonomic sight lines.

Adjustable Leg Levelers

Easily fine-tune the height and levelness of your console with the adjustable leg levelers.

Multiple Corner Options

Standard corner options include 15, 45 and 90 degree concave corners as well as 15 and 45 degree convex corners. Custom corner angles are available as needed to help Spectrum conform to your unique space.

Removable Access Panels

Spectrum features full-length removable rear access panels and lower front removable panels to provide quick, easy access to cables and equipment for simple installation and reduced maintenance time.





SPECTRUM

CONSOLES

MODULAR FLEXIBILITY

Modular Spectrum rack mount consoles are designed to handle a wide range of technical furniture needs and can easily be expanded to keep up with changing technology. Built to last and backed by a 10 year warranty, these consoles stand the test of rigorous 24/7 control room environments. Contact a Winsted sales representative and let us create the perfect configuration for your control room.

FEATURES

- Ergonomically Designed for Comfort
- EIA Standard 19" Tapped Rack Rails
- Flexible Design Solutions
- Customizable as Needed
- Suitable for All Applications





THREE BAY SPECTRUM CORNER CONSOLE

MODEL#	HEIGHT	WIDTH	DEPTH
G3710	35-5/16" (897mm)	85-1/16" (2161mm)	55-1/16" (1399mm)
TOP PANEL	SIDE PANEL	WORK SURFACE	
GRAPHITE NEBULA	GRAPHITE NEBULA	BOTTLE GLASS LAMINATE	

Three bay corner console features two 45 degree corners for a wrap around design. Each bay provides 7" (4U) of sloped rack space along with an articulating monitor arm mounted on Versa-Trak.



FOUR BAY SPECTRUM CONSOLE

MODEL#	HEIGHT	WIDTH	DEPTH
G3711	35-5/16" (897mm)	117-3/4" (2991mm)	44" (1118mm)
TOP PANEL	SIDE PANEL	WORK SURFACE	
GRAPHITE NEBULA	GRAPHITE NEBULA	SANDSTONE MARMOLEUM	

Four bay console can accommodate one or two operators. Comes complete with three articulating monitor mounts on Versa-Trak and features our durable and environmentally friendly Marmoleum work surface.



FIVE BAY CURVED SPECTRUM CONSOLE

MODEL#	HEIGHT	WIDTH	DEPTH
G3712	45-1/2" (1156mm)	147-1/2" (3747mm)	54-7/8" (1394mm)
TOP PANEL	SIDE PANEL	WORK SURFACE	
GRAPHITE NEBULA	GRAPHITE NEBULA	LAVA MARMOLEUM	

Curved Spectrum console is configured with two 15 degree corners and will accommodate one or two operators. Each sloped section provides 15-3/4 (9U) of rack space. Dual radial credenzas offer ample storage space.



SEVEN BAY CONVEX CONSOLE

MODEL#	HEIGHT	WIDTH	DEPTH
G3713	35-5/16" (897mm)	188-7/16" (4786mm)	75" (1905mm)
TOP PANEL	SIDE PANEL	WORK SURFACE	
GRAPHITE NEBULA	GRAPHITE NEBULA	SPECTRUM BLUE LAMINATE	

Convex curved console is configured with six 15 degree corner units. Each bay provides 7" (4U) of sloped rack space and an articulating monitor arm on Versa-Trak. Convex shape creates enough space for seven operators.

20" PULLOUT VTR SHELF WITH LATCHES



MODEL#	DIMENSIONS	WEIGHT
88094 BLACK	1-3/4"H x 17-3/4"W x 20-3/4"D (44 x 451 x 527mm)	17 LBS.

Latches keep the shelf from pulling out when not in use. Shelf has a vented bottom and a recessed area for DVR feet so overall height remains an EIA standard. Extends 20" (508mm).

RACK MOUNT KEYBOARD SHELF



MODEL#	DIMENSIONS	WEIGHT
88397 BLACK	1-3/4"H x 17-1/2"W x 21-5/8"D (44 x 445 x 549mm)	13 LBS.

Mounts into a slope or vertical rack 22-5/8" to 30"D (575-762mm). Holds keyboards up to 16-1/2"W (419mm). Platform provided for mouse.

RACK MOUNT SWIVEL KEYBOARD SHELF



MODEL#	DIMENSIONS	WEIGHT
88398 BLACK	Tray size: 21"W x 15"D (533 x 381mm) Shelf and tray use 3-1/2" (2U) of rack space.	18 LBS.

Mounts into a slope or vertical rack 22-5/8" to 30"D (575 to 762mm). Keyboard tray swivels allowing the use of any standard size keyboard up to 21"W (533mm). Removable platform provided for mouse pad.

13-3/4" W PENCIL DRAWER - BLACK



MODEL#	DIMENSIONS	WEIGHT
55233	2-3/8"H x 13-3/4"W x 18"D (60 x 349 x 457mm)	4 LBS.

Mounts to the underside of any work shelf. This drawer will fit between shelf brackets. Pulls out 12-3/4" (324mm). Black formed plastic.

13-1/2" PULLOUT SHELF

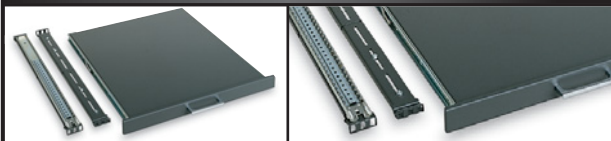

MODEL#	DIMENSIONS	WEIGHT
87099	1-3/4"H x 16-1/2"W x 21-3/4"D (44 x 419 x 552mm)	11 LBS.

Extends 13-1/2" (343mm). Ideal for non-rack mountable electronics. Pearl Grey.

RECESSED PATCH PANEL BRACKET - PAIR

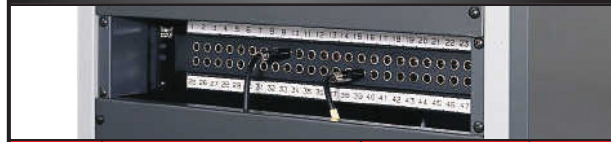

MODEL#	SIZE	COLOR	WEIGHT
86227	3-1/2"H (2U) - pair	PEARL GREY	2 LBS.

Recess a patch panel back into the rack 4" (102mm) to create extra space for the cable connectors. Pearl Grey.

LCD MONITOR RACK KIT - BLACK



MODEL#	DIMENSIONS	WEIGHT
F8153	19-1/16"W x 5-1/4" (3U)H (484 x 133mm)	5 LBS.

Flat Screen Mounting Kit that allows larger LCDs to be mounted in front of the rack face. Black Finish.

STATIC FLAT SCREEN MOUNTING BRACKET - BLACK



MODEL#	DESCRIPTION	WEIGHT
92186	Up to 19" (483mm) Flat Screen with VESA mount. Maximum LCD width 17-3/8" (441mm) 5-1/4" (3U)	4 LBS.

Detachable mounting bracket makes installation quick and easy.

UNIVERSAL RACK MOUNT SHELVES



86071



88095

MODEL#	OVERALL DIMENSIONS	WEIGHT
86071 PEARL GREY	3-1/2" (2U) x 19"W x 18"D (89 x 483 x 457mm) ID 2-7/8"H x 17-3/8"W (73 x 441mm)	8 LBS.
86073 PEARL GREY	5-1/4" (3U) x 19"W x 18"D (133 x 483 x 457mm) ID 4-5/8"H x 17-3/8"W (117 x 441mm)	9 LBS.
88091 BLACK	3-1/2" (2U) x 19"W x 18"D (89 x 483 x 457mm) ID 2-7/8"H x 17-3/8"W (73 x 441mm)	8 LBS.
88093 BLACK	5-1/4" (3U) x 19"W x 18"D (133 x 483 x 457mm) ID 4-5/8"H x 17-3/8"W (117 x 441mm)	9 LBS.
88095 BLACK	8-3/4" (5U) x 19"W x 18"D (222 x 483 x 457mm) ID 8-1/8"H x 17-3/8"W (206 x 441mm)	10 LBS.
88096 BLACK	10-1/2" (6U) x 19"W x 18"D (266 x 483 x 457mm) ID 9-7/8"H x 17-3/8"W (251 x 441mm)	11 LBS.
97091 BLACK	3-1/2" (2U) x 19"W x 12"D (89 x 483 x 305mm) ID 2-7/8"H x 17-3/8"W (73 x 441mm)	6 LBS.

Heavy 14- and 16-gauge steel to assure strength. Fits into any EIA 19"W (483mm) rack. Pearl Grey or Black.

UNIVERSAL EXTRA-DEEP STATIONARY SHELF



86090



88090

MODEL#	DIMENSIONS	WEIGHT
86090 PEARL GREY	3-1/2"H x 19"W x 21-3/4"D (89 x 483 x 552mm)	12 LBS.
88090 BLACK	3-1/2"H x 19"W x 21-3/4"D (89 x 483 x 552mm)	12 LBS.

Designed to attach to the front and back rack rails for extra support. Back rail supports adjust 22" to 30" (559 x 762mm) deep and fit a wide variety of rack cabinets. Inside tray dimensions: 17-3/8"W x 21-3/4"D (441 x 552mm). Requires just 3-1/2" (2U) of rack space. Pearl Grey or Black.

MONITOR BEZELS



Black 1/8" plastic monitor bezel. Uses 19-1/4" (11U) or 21" (12U) of rack space. Use with optional stationary shelf (Model 86088) to support monitor.

MODEL#	SIZE	CUTOUT SIZE	WEIGHT
10989 BLACK	19-1/4" (11U)	19"W x 19-1/4"H (483 x 489mm)	1 LB.
10995 BLACK	21" (12U)	19"W x 21"H (483 x 533mm)	1 LB.

Use a utility knife to cut opening to size. (As shown in photo above.)

3-1/2"H UTILITY DRAWER



MODEL#	DIMENSIONS	WEIGHT
88323 BLACK	3-3/8"H x 16"W x 18"D (86 x 406 x 457mm)	14 LBS.

Rack mountable and/or attaches to the bottom of any flat wood work shelves.

8-3/4"H (5U) UTILITY DRAWER W/LOCK

85321



88321



MODEL#	INSIDE DIMENSIONS	WEIGHT
85321 PEARL GREY	8-3/4"H x 16"W x 19"D (222 x 406 x 483mm)	17 LBS.
88321 BLACK	8-3/4"H x 16"W x 19"D (222 x 406 x 483mm)	17 LBS.

Rack mountable pullout drawer with lock for valuables, power cords, connectors or tools. Pearl Grey or Black.

12-1/4"H (7U) FILE DRAWER W/LOCK - BLACK



88324



MODEL#	INSIDE MEASUREMENT	WEIGHT
88324 BLACK	11-1/2"H x 12-3/16"W x 16-3/4"D (292 x 310 x 425mm)	23 LBS.

Rack mountable letter/legal size file drawer w/side pocket.

KEYBOARD TRAYS

46250



47084

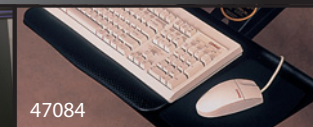

MODEL#	SIZE	WEIGHT
46250	22"W x 9"D (559 x 229mm) - pulls out 12" (305mm)	9 LBS.
47084	24"W x 10"D (610 x 254mm)	11 LBS.

Mounts to the underside of any flat desk top. Outside dimension measures 23-3/4"W (603mm).

Features 20° tilt and 9" (229mm) height adjustment. Shelf swivels 180° and stores under the work surface. Mounts to the underside of any flat desk top. Padded wrist support. Black enamel finish.

RACK MOUNTABLE COOLING FANS - PEARL GREY



MODEL#	DESCRIPTION	WEIGHT
G8591	Single cooling fan. Uses 5-1/4"(3U) of rack space.	3 LBS.
Comes complete with 5-1/4" rack mount vented panel, one 105 CFM cooling fan, five foot electrical cord with plug, metal grill grate for finger protection and two 6" square magnetic vent covers.		
G8592	Dual cooling fans.	4 LBS.
Same as above, except two 105 CFM fans and one 6" square magnetic vent cover.		
G8593	Triple cooling fans.	5 LBS.
Same as above, except three 105 CFM fans.		
G8597	Single cooling fan. Same as above, except one 55 CFM fan.	3 LBS.
G8598	Dual cooling fans. Same as above, except two 55 CFM fans.	5 LBS.
G8599	Triple cooling fans. Same as above, except three 55 CFM fans.	5 LBS.

RACK MOUNTABLE CABINET FANS - PEARL GREY



MODEL#	FANS	DECIBELS	CFM	WEIGHT
G8584	3	55	315	13 LBS.
G8585	6	64	630	16 LBS.
G8586	9	73	945	20 LBS.

Each fan is rated at 105 CFM. Cabinet assembly comes standard with a pre-wired five foot power cord. Textured Pearl Grey finish. Uses 1-3/4" (1U) rack space. Mounts to any 19"W EIA rack. 220 Volt available, contact Winsted.

RACK MOUNT POWER PANELS - BLACK



MODEL#	DESCRIPTION	AMP	CORD LENGTH	WEIGHT
98703	Six-Outlet	15	15' (4.5M)	4 LBS.
Six-outlet - 2 front, 4 back. 15 amp circuit breaker with on/off switch.				
98708	Eight-Outlet	15	15' (4.5M)	4 LBS.
Eight-outlet. Outlets rotated 90° to accept multiple transformer plugs.				
98709	Eight-Outlet	15	15' (4.5M)	4 LBS.
98714	Twelve-Outlet	15	15' (4.5M)	6 LBS.

Rack mount power panels with surge suppressor.

MAGNETIC VENT COVER



MODEL#	DESCRIPTION	WEIGHT
10740	6" x 6" (152 x 152mm)	.5 LBS.

Magnetic panel to cover side panel or door vents. Use when positive air flow is needed from bottom to top in cabinet.

RACK MOUNT TWIN BLOWER - DUAL FANS



MODEL#	FANS	DECIBELS	CFM	WEIGHT
10716	2	58.5	300	15 LBS.

Stainless steel grill with a washable filter and a three foot 3-wire cord. Uses 5-1/4" (3U) rack space. Note: Do not mount behind door.

FAN FILTER ASSEMBLY



MODEL#	TYPE	WEIGHT
10720	Filter with finger guard	.5 LB.

Washable filter covers cooling fans and cleans particles from air before entering cabinet. Black plastic guard.

THERMOSTAT CONTROL

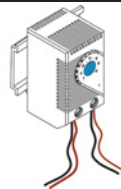

MODEL#	TYPE	WEIGHT
10670	DMS 1141	1 LB.

For inline applications. Set between 32°-140°F (0°-60°C) and the fan(s) will run until the set temperature is reached. Mounts using the supplied DIN rail.

THREE DRAWER FILE CABINET - BLACK



MODEL#	DIMENSIONS	WEIGHT
10765	27"H x 15"W x 17-1/2"D (686 x 381 x 445mm)	70 LBS.
10767	27"H x 15"W x 19-3/4"D (686 x 381 x 502mm)	73 LBS.

Compact cabinet fits neatly under a work surface for storage of files in the bottom drawer. Middle drawer is perfect for items that are 4" high and top drawer works well for paper, pens and pencils. Plastic sliding pencil tray comes with cabinet.

19" WIDE EIA BLANK PANELS



MODEL# PEARL GREY	MODEL# BLACK	HEIGHT	RACK UNIT	WEIGHT
85140	99140	1-3/4" (44mm)	(1U)	1 LB.
85141	99141	3-1/2" (89mm)	(2U)	1 LB.
85142	99142	5-1/4" (133mm)	(3U)	2 LBS.
85143	99143	7" (178mm)	(4U)	3 LBS.
85144	99144	8-3/4" (222mm)	(5U)	3 LBS.
85145	99145	10-1/2" (267mm)	(6U)	4 LBS.
85146	99146	12-1/4" (311mm)	(7U)	4 LBS.
85147	99147	14" (356mm)	(8U)	6 LBS.
85148	99148	15-3/4" (400mm)	(9U)	7 LBS.
85149	99149	19-1/4" (489mm)	(11U)	8 LBS.
85152	99152	24-1/2" (622mm)	(14U)	10 LBS.

Our 16 gauge steel blank panels are flanged for extra strength. They are finished attractively in textured powder coat paint. All sizes are available in Pearl Grey or Black. Just choose the appropriate size blank panel to provide the perfect finishing touch for all of your installations.

PANEL PILOT SCREWS WITH WASHER & CAPTIVE NUTS



MODEL#	QUANTITY	COLOR	WEIGHT
G8051	50 each per pack	Silver	.5 LB.
G8054	50 each per pack	Black	.75 LB.
G8101	100 each per pack	Silver	1 LB.
G8104	100 each per pack	Black	1.5 LBS.
G8056 Security Screws	50 each per pack	Black	1 LB.

Pilot screws make it easy to install your electronics.

ROLL-UP RACK 19-1/4" (11U) CABINET



MODEL#	DESCRIPTION	WEIGHT
E4741	25"H x 24"W x 24"D (635 x 610 x 610mm)	64 LBS.

Includes 2" (51mm) swivel carpet casters. Black Graphite Nebula laminate top and black side panels with black welded steel frame. 19" EIA Equipment Rack.

19"W BEEHIVE VENTED BLANK PANELS - BLACK



MODEL#	HEIGHT	RACK UNIT	WEIGHT
86140	1-3/4" (44mm)	(1U)	.5 LB.
86141	3-1/2" (89mm)	(2U)	.75 LB.
86142	5-1/4" (133mm)	(3U)	1 LB.
86143	7" (178mm)	(4U)	1.5 LBS.
86144	8-3/4" (222mm)	(5U)	2 LBS.
86149	19-1/4" (489mm)	(11U)	4 LBS.
86151	21" (533mm)	(12U)	4 LBS.

Our vented blank panels are available in a variety of sizes and are made from black anodized aluminum. They are flanged for durability and the honeycomb construction provides added ventilation for a variety of rack systems.

BLANK PANEL FILLER KITS WITH BOLTS & CLIPS

KIT	MODEL#	RACK SIZE	COLOR	WEIGHT
1	G8001	4 ea. (1U), 2 ea. (2U), 1 ea. (3U), 1 pk. G8054 Screws & Clips	Pearl Grey	10 LBS.
	G9101	4 ea. (1U), 2 ea. (2U), 1 ea. (3U), 1 pk. G8054 Screws & Clips	Black	10 LBS.
2	G8002	4 ea. (1U), 2 ea. (2U), 1 ea. (9U), 1 pk. G8054 Screws & Clips	Pearl Grey	15 LBS.
	G9102	4 ea. (1U), 2 ea. (2U), 1 ea. (9U), 1 pk. G8054 Screws & Clips	Black	15 LBS.
3	G8003	4 ea. (1U), 2 ea. (2U), 1 ea. (11U), 1 pk. G8054 Screws & Clips	Pearl Grey	16 LBS.
	G9103	4 ea. (1U), 2 ea. (2U), 1 ea. (11U), 1 pk. G8054 Screws & Clips	Black	16 LBS.

BLACK RACK RAIL TRIM

MODEL#	DIMENSIONS	WEIGHT
85744	Sold in 1 ft. increments	.5 LB.

Made of flexible PVC with internal metal clips to provide a permanent grip. Trim has a fine pebble finish to dress up your installation. Use to cover unused rack rail holes. Trim can be cut to size with a scissors.

PULLOUT, SWIVEL CPU MOUNT

MODEL#	DESCRIPTION	WEIGHT
46260	Extends forward with 90° swivel	15 LBS.

Fits CPU's from 13-1/2" to 21-1/2" High (343 to 546mm) by 5-3/8" to 9-3/8" Wide (137 to 238mm). Black finish.

WINSTED WARRANTY

- A **LIFETIME WARRANTY** on all fixed steel structure frame components.
- A **10 year warranty** on adjustable, sliding or hinged components and laminated & Marmoleum surfaces.
- A **5 year warranty** on Endurance Plus and TruForm surfaces.
- A **2 year warranty** on all electrical components and chairs.

All warranties are effective from date of shipment. All products shall be free from defects in material and workmanship under normal usage and conditions for which the products were designed.

Winsted's obligation under this warranty shall be limited to the exchange of the product or parts that proved to be defective or unsatisfactory. Winsted reserves the right to have the product inspected at the buyer's location or have the product returned to the factory for inspection. The above warranty does not extend to consumable products, goods damaged or subjected to accident, abuse or misuse after shipment from Winsted's factory or to goods that are altered or modified.



VALUE

Winsted provides support second to none in the industry. Trained representatives gather project information, give design support to help lay out the project and even provide infield support.

PRODUCT DEVELOPMENT

This process never stops. Winsted is known as the industry leader. We provide new solutions daily as technology continues to change.

AVAILABILITY

Winsted supplies metal consoles and racks from stock, with custom wood and Corian finishes available within 4 weeks.

FREIGHT

Call Winsted for your free freight quotation, this takes the guesswork out of the quotation. We can provide CIF quotations for all orders, which helps the customer understand the true cost of the product.

FLAT-PACKED, PRE-ASSEMBLED, INSTALLED

Winsted will drop-ship orders directly. Every order has three options for shipment:

- 1. Flat-packed -**
Reduces shipping costs and provides the fastest delivery.
- 2. Pre-assembled prior to shipping -**
Reduces customer set-up time.
- 3. Installed -**
Product installed by trained Winsted technicians. Call for on-site installation cost.

CUSTOMER SERVICE

Specialists are individually empowered to handle issues and resolve situations efficiently and fairly.

PRODUCT OFFERING

Winsted offers the most complete line of products in the industry, designed to fit a variety of needs within almost any organization. From control room consoles and military command centers, to network operation centers and process control applications. Winsted pledges to provide products that meet today's needs, as well as anticipating future technology requirements.

SATISFACTION GUARANTEED

Winsted Products are guaranteed to be free of manufacturing defects. If any product is determined to be unsatisfactory, call our Customer Service Department Toll-Free 800.447.2257. Our policy is that you must be completely satisfied with our products. For fast service or for additional product information call Toll-Free 800.447.2257.

SHIPPING

All shipments are F.O.B. shipping point. Every attempt will be made to ship your order as soon as possible via the most direct and economical way. If a specific carrier is preferred, the purchase order must be clearly marked.

LIABILITY

No liability is assumed by our company for damage and/or injury resulting from use of products supplied by this company.

CREDIT

For new accounts that have not established credit with Winsted, a sufficient amount of time should be allowed to obtain proper credit information. Please be sure to provide your bank information and two trade references with initial order. If immediate shipment of order is desired, ship C.O.D. or send check for full amount with order or call with credit card information. Special order merchandise and large orders may require 50% cash in advance before shipping.

DROP SHIPMENTS

Winsted will ship orders directly to any authorized dealer's customer. Drop shipments are sent pre-paid with freight charges, plus a small handling charge added to the dealer's invoice.

FREIGHT SHORTAGES OR DAMAGES

All shipments should be inspected carefully upon receipt. Before signing the freight bill have the delivering carrier note any damage, shortage or loss in writing on the freight bill. Concealed damage must be reported to Winsted within 15 days. Failure to do so places responsibility for loss with the consignee.

RETURNED GOODS

No merchandise may be returned without prior authorization. Custom items will not be accepted on a return. Call Toll-Free 800.447.2257 to our Customer Service Department and obtain a "Return Authorization Number." All returns are to be prepaid. All return merchandise is subject to a 15% restocking and handling charge. Credit will be issued provided products are returned in undamaged condition, and in their original packaging.

TERMS OF SALE

Terms are Net 30 days, upon credit approval. Outstanding past due balances are subject to a financing charge of 1-1/2% per month. All terms, conditions, specifications and prices are subject to change without notice.



PROFESSIONAL GRADE

Winsted Custom Wood offers the highest quality architectural woodwork and commercial cabinetry for all installations. We can custom manufacture to your specifications or you can work with our expert designers to create a one-of-a-kind environment. Your timeline and budget are a priority and we work hard to achieve both.

CUSTOM WOOD FURNITURE

We specialize in consoles but we offer so much more! In 2011 Winsted launched a new Custom Wood Division to design and manufacture wood products for today's demanding control room environments. In forming the new division we added a state-of-the-art production facility as well as many skilled craftsmen with years of woodworking experience.

Moving beyond the control room, we also provide custom technical furniture solutions for other technology-heavy spaces. Our 50-plus years of control room experience puts us in a unique position to manage the technical complexities and the human factors necessary to create a world class environment. We can compliment your control room with the following:

- Reception Desks
- Lobby Consoles
- Conference Room Tables
- Operator Pods
- File Cabinets
- Custom Cabinetry
- Wood Consoles
- Credenzas
- Collaboration Tables
- Technology Tables
- Podiums
- Bookcases
- Workstations
- Work Surfaces
- Casework
- Accessories





VERSATILITY

Bookcases, file cabinets, podiums, benches, storage cabinets and other wood products are custom designed and manufactured to meet your specifications. Bring us your design or let us create a unique solution for you. Either way the end result will be something you can be proud of.





JOIN THE TEAM

Furniture and technology combined to create the ideal solution for exchanging ideas and encouraging collaborative solutions. From the boardroom to the classroom, our collaboration tables can be custom made in a variety of shapes, sizes, configurations and finishes. The work surface can be standard desk height or standing height and can accommodate a wide range of electrical, data and A/V components.



COLLABORATION TABLE WITH STANDARD BASE

MODEL#	DIMENSIONS
M1152	30"H x 48"W x 72"D (762 x 1219 x 1829mm)

The M1152 collaboration table features a durable, high-pressure laminate top with our proprietary Safeguard Edge. Choose from hundreds of standard laminate top colors. The black base incorporates a wire management trough and access panels for proper cable management. Optional data/power ports not included. A wide variety of data/power ports are available. Contact Winsted for details.



STAND-UP COLLABORATION TABLE

MODEL#	DIMENSIONS
M1153	41"H x 48"W x 72"D (1041 x 1219 x 1829mm)

The M1153 collaboration table features a durable, high-pressure laminate top with our proprietary Safeguard Edge. Choose from hundreds of standard laminate top colors. The black stand-up base with footrest incorporates a wire management trough and hinged doors for easy access. Optional data/power ports not included. A wide variety of data/power ports are available. Contact Winsted for details.



STAND-UP COLLABORATION TABLE W/ MONITOR WALL

MODEL#	DIMENSIONS
M1154	72"H x 60"W x 77"D (1829 x 1524 x 1956mm)

The M1154 collaboration table features a durable, high-pressure laminate top with our proprietary Safeguard Edge. Choose from hundreds of standard laminate colors for the table top and monitor wall. The black stand-up base with footrest incorporates a wire management trough and access panels for proper cable management. Optional data/power ports not included. A wide variety of data/power ports are available. Contact Winsted for details.



COLLABORATION TABLE W/ RECESSED MONITOR IN WALL

MODEL#	DIMENSIONS
M1155	72"H x 60"W x 77"D (1829 x 1524 x 1956mm)

The M1155 collaboration table features a durable, high-pressure laminate top with our proprietary Safeguard Edge. Choose from hundreds of standard laminate colors for the table top and monitor wall. The black base incorporates a wire management trough and hinged doors for easy access. Optional data/power ports not included. A wide variety of data/power ports are available. Contact Winsted for details.



CONFERENCE ROOM TABLES

In many cases, the conference room table is a signature piece of furniture and makes a lasting impression of the organization. Our conference room tables and furnishings are elegant, functional and designed to last a lifetime. Our custom conference room tables are built from the finest materials available.



M4554

OVAL CONFERENCE TABLE

MODEL#	DIMENSIONS
M4552	30"H x 54"W x 96"D (762 x 1372 x 2438mm)

This stylish oval conference room table features a durable, high-pressure laminate top with our proprietary Safeguard Edge. Choose from hundreds of standard laminate top colors. The black base incorporates a wire management trough and access panels for proper cable management. A wide variety of optional data/power ports are available. Contact Winsted for details.

RACETRACK CONFERENCE TABLES

MODEL#	DIMENSIONS
M4554	30"H x 42"W x 120"D (762 x 1067 x 3048mm)
M4557	30"H x 42"W x 156"D (762 x 1067 x 3962mm)

These contemporary racetrack shaped conference room tables feature a durable, high-pressure laminate top with our proprietary Safeguard Edge. Choose from hundreds of standard laminate top colors. The black base incorporates a wire management trough and access panels for proper cable management. A wide variety of optional data/power ports are available. Contact Winsted for details.



M4568

BOAT-SHAPED CONFERENCE TABLE

MODEL#	DIMENSIONS
M4563	30"H x 48"W x 108"D (762 x 1219 x 2743mm)

This elegant boat-shaped room table features a durable, high-pressure laminate top with our proprietary Safeguard Edge. Choose from hundreds of standard laminate top colors. The black base incorporates a wire management trough and access panels for proper cable management. A wide variety of optional data/power ports are available. Contact Winsted for details.

LARGE BOAT-SHAPED CONFERENCE TABLES

MODEL#	DIMENSIONS
M4566	30"H x 48"W x 144"D (762 x 1219 x 3658mm)
M4568	30"H x 48"W x 168"D (762 x 1219 x 4267mm)

These spacious boat-shaped room tables feature a durable, high-pressure laminate top with our proprietary Safeguard Edge. Choose from hundreds of standard laminate top colors. The black base incorporates a wire management trough and access panels for proper cable management. A wide variety of optional data/power ports are available. Contact Winsted for details.

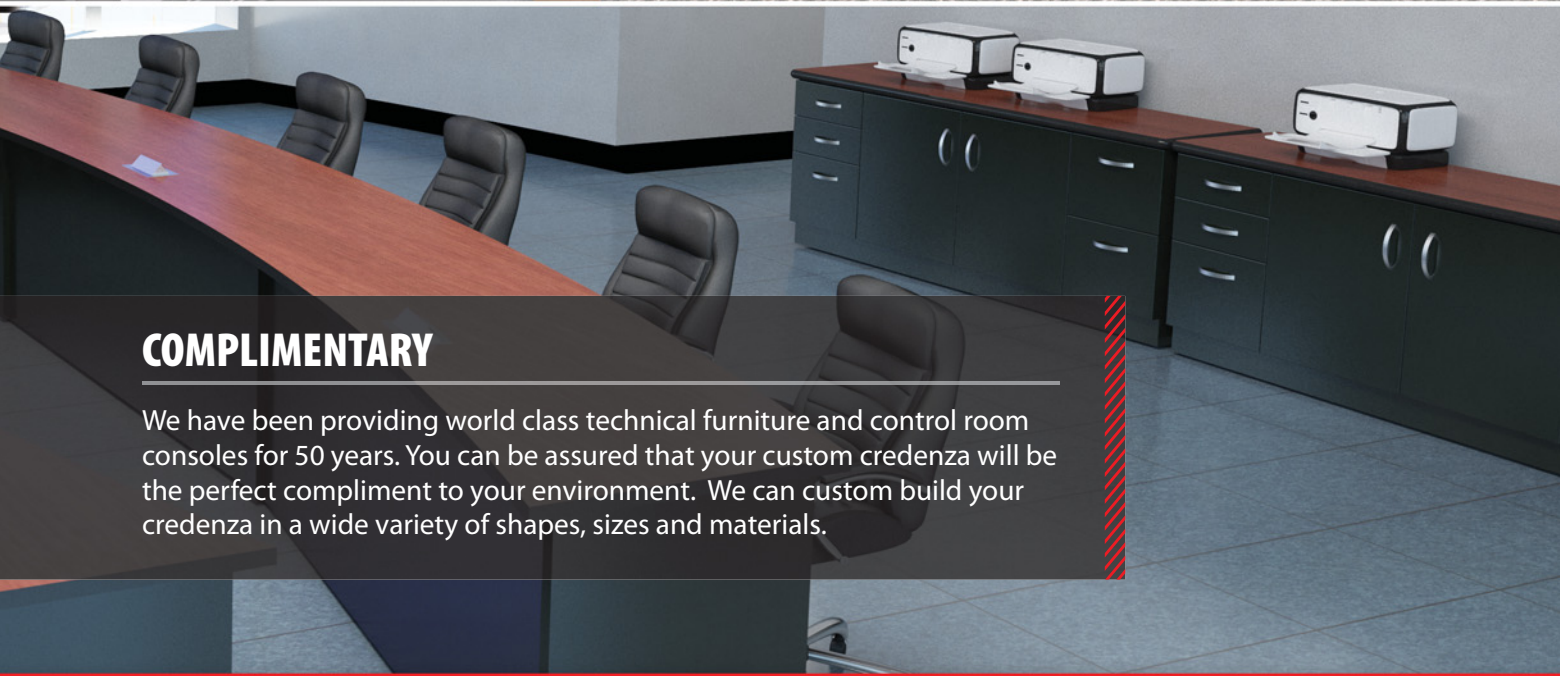

COMPLIMENTARY

We have been providing world class technical furniture and control room consoles for 50 years. You can be assured that your custom credenza will be the perfect compliment to your environment. We can custom build your credenza in a wide variety of shapes, sizes and materials.

TWO-DRAWER FILE CABINET

MODEL#	DESCRIPTION
15500	Letter Sized File Cabinet. Custom Colors Available.
Overall Dimensions: 31"H x 18-1/4"W x 20"D (787 x 464 x 508mm).	



15500

BOOKCASE

MODEL#	DESCRIPTION
15580	36" Wide Bookshelf. Custom Colors and Sizes Available.
Overall Dimensions: 48"H x 36"W x 13"D (1219 x 914 x 330mm).	



15580

SINGLE-FILE CREDENZA WITH STORAGE

MODEL#	DESCRIPTION	TOP SURFACE
M1505	Single-File Credenza with Storage	Corian
M1504	Single-File Credenza with Storage	Comfort Edge
M1503	Single-File Credenza with Storage	Endurance Plus
M1502	Single-File Credenza with Storage	Laminate
M1501	Single-File Credenza with Storage	Marmoleum
Overall Dimensions: 30-3/4"H x 72"W x 20"D (781 x 1829 x 508mm).		



M1504

BOOKSHELF CREDENZA WITH STORAGE

MODEL#	DESCRIPTION	TOP SURFACE
M1515	Bookshelf Credenza with Storage	Corian
M1514	Bookshelf Credenza with Storage	Comfort Edge
M1513	Bookshelf Credenza with Storage	Endurance Plus
M1512	Bookshelf Credenza with Storage	Laminate
M1511	Bookshelf Credenza with Storage	Marmoleum
Overall Dimensions: 30-3/4"H x 72"W x 20"D (781 x 1829 x 508mm).		



M1513

DUAL-FILE CREDENZA WITH STORAGE

MODEL#	DESCRIPTION	TOP SURFACE
M1525	Dual-File Credenza with Storage	Corian
M1524	Dual-File Credenza with Storage	Comfort Edge
M1523	Dual-File Credenza with Storage	Endurance Plus
M1522	Dual-File Credenza with Storage	Laminate
M1521	Dual-File Credenza with Storage	Marmoleum
Overall Dimensions: 30-3/4"H x 72"W x 20"D (781 x 1829 x 508mm).		



M1525



FROM CONCEPT > TO REALITY

Winsted Custom Division starts with your criteria, and we develop a solution that exactly fits your needs instead of trying to meet your requirements with pre-configured modules. Your solution is designed for YOUR application to exactly match your requirements, space and functionality. We combine the disciplines of industrial design, human factors and interior design to create workspaces that are both efficient and beautiful. We carefully consider the ergonomic requirements of your

operators to design consoles and technical furniture that facilitate the complex interactions between personnel, technology and the environment. We work with you to develop custom console solutions for every possible control room application, regardless of the scale or complexity.

THE MOST DEMANDING INSTALLATIONS

Winsted's custom consoles are installed in nuclear power plants, military command centers, security control rooms and mission critical communication centers around the world. From the layout of the room, to determining the precise placement of every keyboard, monitor and telephone, not a single detail is left to chance. Below is an outline of the comprehensive process we go through to make sure the final installation exceeds your highest expectations.



CONSULTATION

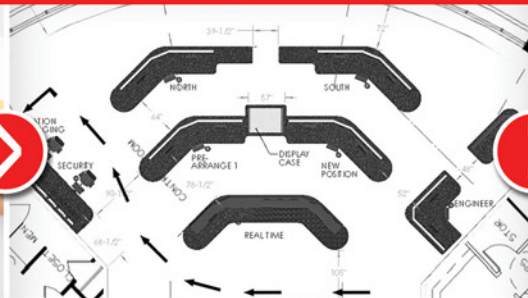

PRELIMINARY DESIGN

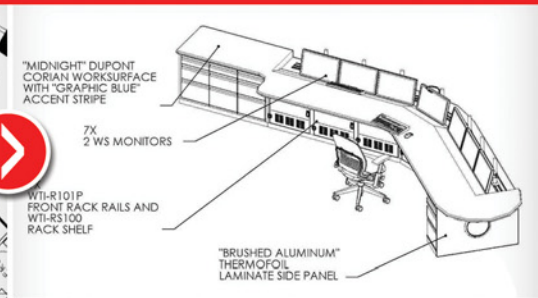

REFINEMENT OF DESIGN

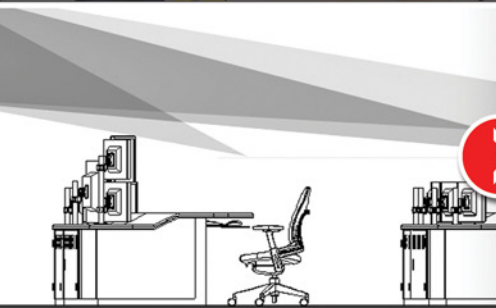

ERGONOMIC EVALUATION



FULL COLOR RENDERING

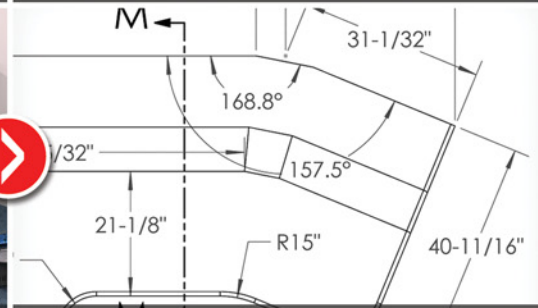

ENGINEERING OF FABRICATION DRAWINGS



FABRICATION



DRY FIT AND INSPECTION

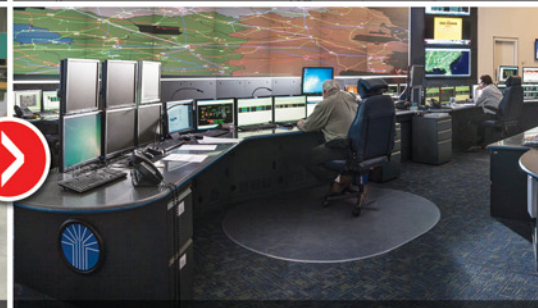

FINAL INSTALLATION

BUILT BY HAND > BUILT TO LAST



Raw steel is cut to size



Frames are welded together



Quality assurance checks throughout process

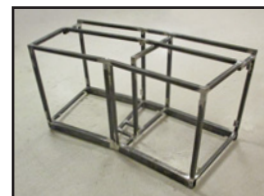

Welded and ground Frame ready for powder coat



Assembly of powder coated parts and other components



CNC Corian fabrication



Complete dryfit in shop before shipping



Final buffing and finishing onsite during installation

+ ACCESSORIES

+ FEATURES

- Ergonomic Recess for Improved Sightlines
- Seamless Corian® Work Surface
- Mobile or Integrated File Cabinets
- Cabinet Leveling Feet
- Vented Hinged Doors
- 3" Pole with Mount for Large Monitors and Sound Showers
- Adjustable Monitor Mounts
- Aurora Articulating LED Task Light
- Adapt-A-Track and Upper Cable Raceway
- Welded Tube Steel Frames
- Pull-Out Pencil Drawer
- Tapped Rack Rails with Adjustable Shelves
- Removable Base Pan with Lower Cable Raceway



Winsted[®]

Control Room Consoles

**CUSTOM
DIVISION**

CUSTOM HEIGHT-ADJUSTABLE CONSOLES

Our designers and project managers work closely with A&E firms, contractors and in-house engineers to facilitate everything from initial control center designs to final installation. From single consoles to complete command centers we have the experience and resources to build each project to your every specification.

Public Transit Control Room



Refinery Control Room



Power Distribution Control Room



FORM AND FUNCTION

With every project we strive to create the perfect balance between form and function. Our ergonomic designs maximize operator comfort and productivity, while our aesthetic options such as custom woodworking achieve a truly superior upscale appearance. Contact one of our designers today and let us help you create the perfect custom solution.

Dual Height-Adjustable Console



Extensive Finish Options Available



Automated Monitor Lifts



NUCLEAR CONTROL ROOMS

Control rooms for nuclear plants are without a doubt some of the most complex. Safety and security is a chief concern for these power plants and a primary focus of control room design. An ergonomic approach to the design of control workstations and the layout of the control room contributes to achieving their strict safety and performance objectives.



Custom Touch Screen Turrets Available

Modular Nuclear Research Simulator - CASE STUDY: winsted.com/uv

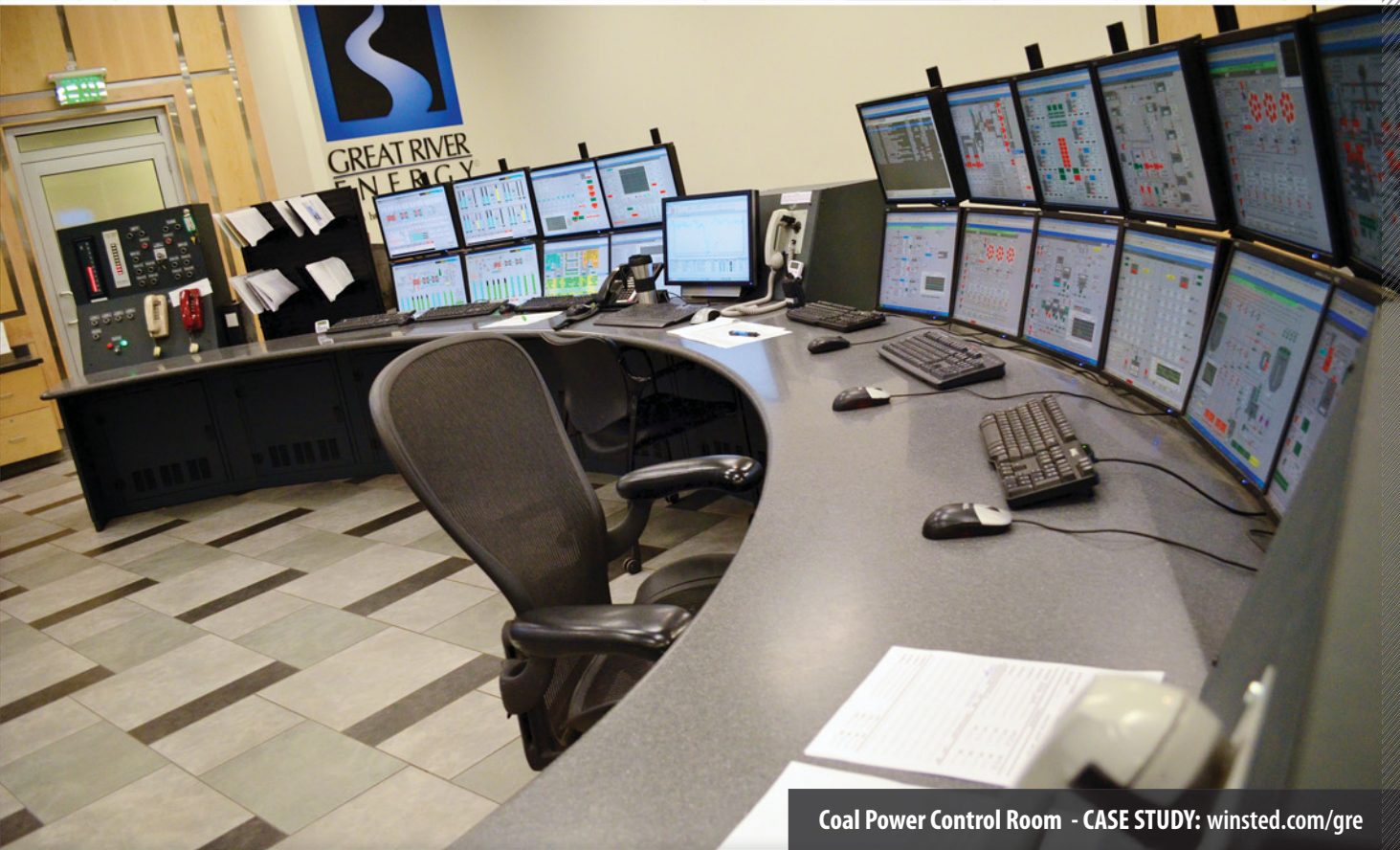

Coal Power Control Room - CASE STUDY: winsted.com/gre

Winsted®

Control Room Consoles

**CUSTOM
DIVISION**



Georgia System Operations



Transmission & Distribution - CASE STUDY: winsted.com/gsoc



Talon 2 Console



CUSTOM CONSOLES BUILT TO YOUR ROOM SPECIFICATIONS

We work around columns, analyze walkways, and design consoles around user specific tasks. Designed to enhance the human decision making process in critical situations. The operators will do their job without eyestrain, feeling cramped or reaching too far for the controls

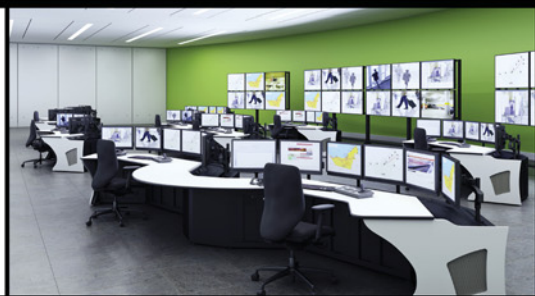
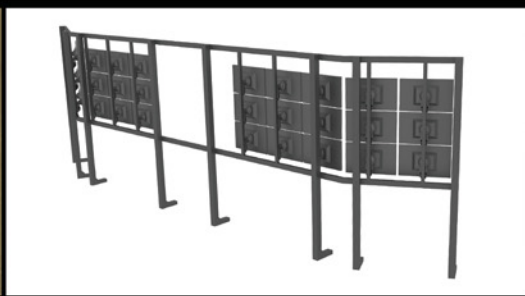
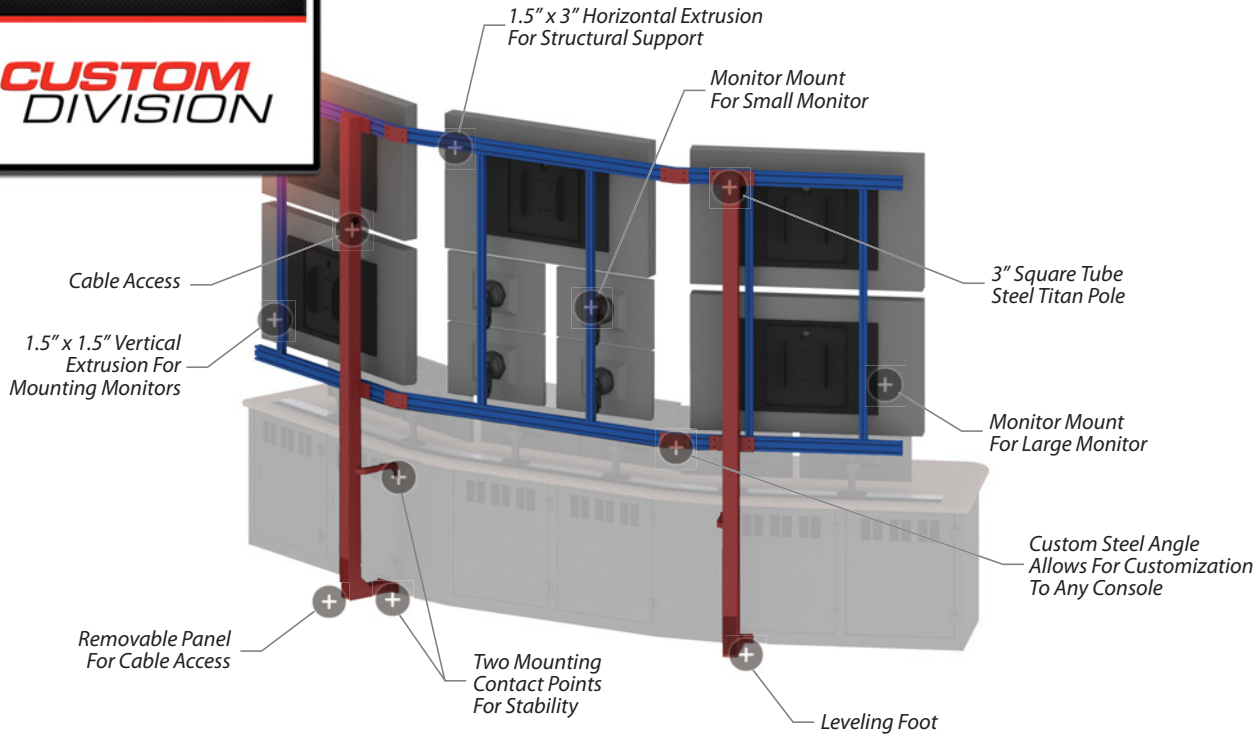

SKY TRACK™ MONITOR WALL FEATURES

- Mount multiple large monitors to the console base instead of a wall
- Update your existing console with the Sky Track System
- Provides the ability to control monitor viewing distances
- Versatile Sky Track can handle changes in monitor sizes
- Removable panel on 3" Titan pole provides access to wiring
- Leveling foot for height adjustment and stability
- Can be added to all Prestige, Custom, and existing consoles

Custom configurations available for any control room installation, large or small.



CUSTOM HORIZON FEATURES

- Comfort Edge work surface, electric lift legs and height-adjustable cable raceways
- Dual and single height-adjustable consoles are available
- 102"W with 42"D dual work surface, ask about the size you need
- Variety of monitor mounting configurations available
- Height adjustability from 27.5" - 47"
- Please ask about custom shapes, sizes, features and colors

Many other colors available. Go to page 22-27 for additional work surface colors, including corian.

PLASTIC WIRE DUCT



MODEL#	SIZE	COLOR	WEIGHT
42750	4"H x 2"W x 72"L (102 x 51 x 1829mm)	Black	2 LBS.
42752	2"H x 4"W x 78"L (51 x 102 x 1981mm)	Black	3 LBS.
42755	4"H x 4"W x 72"L (102 x 102 x 1829mm)	Black	4 LBS.
42757	2"H x 2"W x 78"L (51 x 51 x 1981mm)	Black	2 LBS.

Wire ducts are slotted and come complete with cover except 42750.

42756	1-1/2"H x 1-1/2"W x 72"L (38 x 38 x 1829mm)	Black	2 LBS.
-------	---	-------	--------

42756 has solid walls and comes complete with cover.

KEYBOARD TRAYS



MODEL#	SIZE	WEIGHT
46250	22"W x 9"D (559 x 229mm) - pulls out 12" (305mm)	9 LBS.

Mounts to the underside of any flat desk top. Outside dimension measures 23-3/4"W (603mm).

47084	24"W x 10"D (610 x 254mm)	11 LBS.
-------	---------------------------	---------

Features 20° tilt and 9" (229mm) height adjustment. Shelf swivels 180° and stores under the work surface. Mounts to the underside of any flat desk top. Padded wrist support. Black enamel finish.

MAGNETIC VENT COVER

MODEL#	TYPE	WEIGHT
10740	6" x 6" (152 x 152mm)	.5 LBS.

Magnetic panel to cover side panel or door vents. Use when positive air flow is needed from bottom to top in cabinet.

POWER SUPPLY OUTLETS

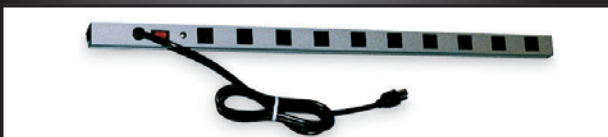

MODEL#	DESCRIPTION	AMP	CORD LENGTH	WEIGHT
10710	34" - Ten-outlet	15	72" (1829mm)	4 LBS.
10712	69" - Ten-outlet	15	72" (1829mm)	6 LBS.
10713	68" - Twenty-outlet	15	180" (4572mm)	7 LBS.
10684	70" - Eleven-outlet	20	72" (1829mm)	8 LBS.

Lighted On/Off switch. Mounts to the back of any base/slope rack combination, Spectrum Console or vertical rack. Also mounts horizontally in all consoles.

THREE DRAWER FILE CABINET - BLACK



MODEL#	DIMENSIONS	WEIGHT
10765	27"H x 15"W x 17-1/2"D (686 x 381 x 445mm)	70 LBS.
10767	27"H x 15"W x 19-3/4"D (686 x 381 x 502mm)	73 LBS.

Compact cabinet fits neatly under a work surface for storage of files in the bottom drawer. Middle drawer is perfect for items that are 4" high and top drawer works well for paper, pens and pencils. Plastic sliding pencil tray comes with cabinet. Master key - 10743

LED TASK LIGHTS



MODEL#	DIMENSIONS	WEIGHT
56679	LED light with magnetic base and 18" (457mm) flexible neck	1 LB.
10679	LED light with VESA mount and 18" (457mm) flexible neck	1 LB.

Features a 6-foot cord and allows users to switch between a white & red light.

MASTER KEY

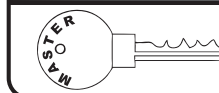

MODEL#	DIMENSIONS	WEIGHT
85743	MK-500 Master Key	.5 LB.

Single key to open your locking doors.

VELCRO STRAP - BLACK



MODEL#	DESCRIPTION	WEIGHT
12765	Velcro Strap 1" x 96" long (25 x 2438mm)	.5 LB.

Perfect for securing electronics to a shelf.

PULLOUT, SWIVEL CPU MOUNT



MODEL#	DESCRIPTION	WEIGHT
46260	Extends forward with 90° swivel	15 LBS.

Fits CPU's from 13-1/2" to 21-1/2" High (343 to 546mm) by 5-3/8" to 9-3/8" Wide (137 to 238mm). Black finish. Does not fit E-SOC.

3-1/2"H UTILITY DRAWER - BLACK



MODEL#	DIMENSIONS	WEIGHT
88323	3-3/8"H x 16"W x 18"D (86 x 406 x 457mm)	14 LBS.

Rack mountable and/or attaches to the bottom of any flat wood work shelves.

SECTIONAL WALL MOUNT CABINETS - BLACK

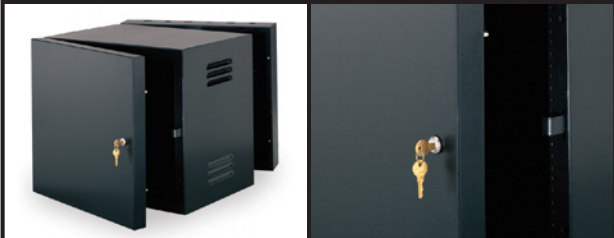

MODEL#	RACK HEIGHT	OVERALL DIMENSIONS	WEIGHT
97020	15-3/4"H (9U)	19"H x 21"W x 22-1/4"D (483 x 533 x 565mm)	64 LBS.
97026	28"H (16U)	31-1/4"H x 21"W x 22-1/4"D (794 x 533 x 565mm)	92 LBS.

Made from heavy-gauge steel with 10-32 tapped front rack rails, louvered sides and 270° hinges. This symmetrical cabinet hinges either left or right. Key locking front door. Cabinet section depths: 4-1/2"D (114mm) rear, 16"D (406mm) center, 1-3/4"D (44mm) front. Maximum wt. load 100 lbs.

SECURITY CABINET W/HINGED DOOR - BLACK



MODEL#	OVERALL DIMENSIONS	WEIGHT
96030	9-1/2"H x 19-1/2"W x 23"D (241 x 495 x 584mm)	28 LBS.

Heavy-duty locking cabinet for DVR/VTR and controllers, comes with rear cord access slot and vent holes for 10705 cooling fan.

WALL MOUNT MONITOR SHELVES



MODEL#	OVERALL DIMENSIONS	WEIGHT
11081	17"W x 18"D (432 x 457 mm) with 1/2"H (13mm) front retainer lip	10 LBS.
11093	10"H x 18"W x 17"D (254 x 457 x 432mm)	19 LBS.

16" centers for wall mounting along with adjustable tilting tray for better viewing angle. 5/16" x 1-1/2" (8 x 38mm) long slots for 96"L (2.4m) monitor safety strap (included). Pearl Grey Finish.

Supports both electronics on one shelf. Opening size: 5-5/8"H x 17-7/8"W (143x 454mm). 16-gauge steel. Maximum weight 80 lbs. 16" Center wall mounting. Black Finish.

24-1/2" LOCKING SECURITY CABINET - BLACK



MODEL#	OVERALL DIMENSIONS	WEIGHT
G9939	Extra-Deep - 26-5/8"H x 22-5/8"W x 25-1/2"D (676 x 575 x 648mm)	87 LBS.

Cabinet sits on desk or wall mount, front door is 1-1/4" deep for electronic clearance and symmetrical for left- or right-hand mounting. 19" depth from front rack rail to inside back. NEMA electrical knockouts.

ROLL-UP RACK 19-1/4" (11U) CABINET



MODEL#	DESCRIPTION	WEIGHT
E4741	25"H x 24"W x 24"D (635 x 610 x 610mm)	64 LBS.

Includes 2" (51mm) swivel carpet casters. Black Graphite Nebula laminate top and black side panels with black welded steel frame. 19" EIA Equipment Rack.

DESKTOP POWER GROMMET



MODEL#	MEASUREMENT	WEIGHT
10660	4-3/8" Outer Ring Requires 4.21" Hole Cut Size	1 LB.

Easily converts any desk, table or work surface into a ready-to-access power center. Simply rotate the grommet with it's easy 180° rotation system and the grommet is ready to use.

- 3 Grounded power outlets
- 2 Cat 5 ethernet connections
- 8 ft. Power cord

FREE DESIGN SERVICE

CHAIRS



11745 - 24/7 Chair

Shown with optional scoop arms 11769



11760 - Task Chair



11762 - Task Chair - RED

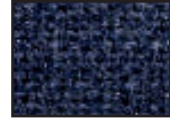

11766 - Task Chair - BLUE



11760 - Task Chair - BLACK

MODEL#	DESCRIPTION	MEASUREMENTS	COLOR	WEIGHT
11745	24/7 High Back Chair	38-3/4 - 43"H x 26-1/2"W x 25"D (984-1092 x 673 x 635mm)	Black	52 LBS.
Contemporary design with superior comfort meets simplicity with high-performing functionality in this 24/7 chair designed for demanding control room operations. A suspension mesh back design regulates temperature for long-term comfort, healthy sitting and proper back support. Adjustable arms, back and seat ensure proper fit for every size. Arms come standard.				
11760	Universal Task Chair	37- 42"H x 21"W x 26"D (940-1067 x 533 x 660mm)	Black	42 LBS.
Sit soft all day in comfort with independent seat tilt, front tilt, independent back tilt, lock in a desired angle or free float. Pneumatic height adjustment and height adjustable back with knob adjustment. Two layers of 3" high density foam covered in a high quality Olefin/Polyester fabric. Seat and back meet CA 117 fire code. Optional arms available (see 11769 below).				
11769	Optional Scoop Arms - set of two		Black	8 LBS.
Durable poly arm pads with push button adjustability. Task Chair only.				



E4727

SINGLE CABINET GRAPHICS DESK

MODEL#	HEIGHT	WIDTH	DEPTH
E4727	29" (737mm)	60" (1524mm)	30" (762mm)
COLOR	ACCENT COLOR	WEIGHT	
BLACK	OPTIONAL (BLUE SHOWN)	201 LBS.	

Black Graphite Nebula laminate top with black contour trim edging. Black rack cabinet offers 24-1/2" (14U) of rack space. Rack cabinet can be positioned for either left or right hand operations.

INDEX: (MODEL NUMBER - PAGE NUMBER)

10220	60	51239	55	85147	70	90112	58	B3013	38	G8586	69	M4563	79
10660	95	51710	17	85148	70	90116	58	B3015	38	G8591	69	M4566	79
10670	69	55233	48	85149	70	90118	58	B3017	38	G8592	69	M4568	79
10679	16	56029	18	85152	70	90122	58	B3023	38	G8593	69	V4211	61
10684	94	56030	16	85276	60	90126	58	B3025	38	G8597	69	V4221	61
10705	61	56032	16	85321	68	90129	58	B3027	38	G8598	69	V9019	58
10710	94	56036	16	85743	94	90132	58	B3033	38	G8599	69	V9021	58
10712	94	56087	16	85744	70	90136	58	B3035	38	G9085	59	W5630	16
10713	94	56088	16	85782	59	90138	58	B3037	38	G9101	70	W5631	16
10716	69	56115	20	86071	68	90262	59	B3043	38	G9102	70	W5642	16
10720	69	56165	16	86073	68	90266	59	B3045	38	G9103	70	W5650	17
10724	61	56220	17	86090	68	90267	60	B3047	38	G9939	95	W5660	16
10725	61	56250	17	86140	70	90269	59	B3053	40	M1020	55	W5661	16
10740	69	56264	17	86141	70	90270	59	B3055	40	M1021	55	W5664	16
10764	18	56265	17	86142	70	90271	60	B3056	41	M1022	55	W5665	16
10765	94	56566	17	86143	70	90273	60	B3061	39	M1023	55	W5690	14
10767	94	56568	17	86144	70	90312	59	B3062	39	M1030	55	W5698	14
10800	59	56569	17	86149	70	90316	59	B3063	39	M1032	55	W5701	12
10814	59	56570	17	86151	70	90318	59	B3064	39	M1034	55	W5721	12
10989	68	56679	16	86227	67	90322	59	B3098	41	M1100	54	W5737	13
10995	68	56719	20	87099	67	90326	59	B3099	41	M1102	54	W5738	13
11081	95	56720	20	88090	68	90328	59	B3210	32	M1104	54	W5772	14
11093	95	56721	20	88091	68	90332	59	B3230	32	M1106	54	W5773	14
11104	55	56726	20	88093	68	90336	59	B3250	32	M1108	54	W5774	14
11745	96	56728	20	88094	60	90338	59	B4312	46	M1121	54	W5775	14
11760	96	56730	20	88095	68	90661	60	B4314	46	M1123	54	W5776	14
11762	96	56751	21	88096	68	90662	60	B4316	46	M1125	54	W5777	14
11766	96	56752	21	88217	60	90663	60	B4324	46	M1127	54	W5778	14
11769	96	56754	21	88218	60	90664	60	B4350	47	M1129	54	W5780	18
12765	94	56755	21	88220	60	92186	67	B4351	47	M1152	77	W5781	18
15500	81	56981	16	88226	60	96030	95	B4352	47	M1153	77	W5830	12
15580	81	58160	15	88321	68	97020	95	B4353	47	M1154	77	W5831	12
30031	40	58161	15	88323	94	97026	95	E4727	96	M1155	77	W5900	17
30080	41	58162	15	88324	68	97091	68	E4741	95	M1501	81	W6407	13
30172	40	58171	15	88397	61	98703	69	E5081	14	M1502	81	W6408	13
30175	40	58174	15	88398	61	98708	69	F8153	67	M1503	81	W6430	16
30178	40	58178	15	90012	58	98709	69	G3710	66	M1504	81	W6431	16
30701	41	64032	16	90016	58	98714	69	G3711	66	M1505	81	W6469	17
32087	33	64072	18	90018	58	99140	70	G3712	66	M1511	81	W6471	14
42750	94	64074	18	90022	58	99141	70	G3713	66	M1512	81	W6472	14
42752	94	64076	18	90026	58	99142	70	G8001	70	M1513	81	W6473	14
42755	94	64100	18	90028	58	99143	70	G8002	70	M1514	81	W6491	14
42756	94	64264	17	90032	58	99144	70	G8003	70	M1515	81	W6492	14
42757	94	64719	20	90036	58	99145	70	G8051	70	M1521	81	W6493	14
43009	48	85140	70	90038	58	99146	70	G8054	70	M1522	81	W6496	14
43032	48	85141	70	90051	59	99147	70	G8056	70	M1523	81	W6497	14
43260	48	85142	70	90053	59	99148	70	G8060	60	M1524	81	W6500	17
46250	94	85143	70	90055	59	99149	70	G8101	70	M1525	81		
46260	94	85144	70	90072	59	99152	70	G8104	70	M4552	79		
47084	94	85145	70	90076	59	99484	61	G8584	69	M4554	79		
51237	55	85146	70	90078	59	99488	61	G8585	69	M4557	79		

AT YOUR SERVICE - FROM CONCEPT TO INSTALLATION



FREE ON-SITE CONSULTATION

We understand that every installation is unique and we can gather valuable information by visiting the actual site. We are committed to getting it right the first time and, at no charge, we will travel to your location to take measurements, do a site survey and consult with the appropriate parties.

FREE DESIGN SERVICE

FREE DESIGN SERVICE

We go to great lengths to understand your needs and the objectives of the project. Our experienced design department will design your console to be ergonomically correct and to support the associated electronics and equipment. Once the design is final we will provide you with a complete design and specification package ready for presentation.

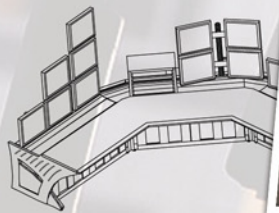

FREE PROJECT SUPPORT

Winsted is a true project partner and we pride ourselves on going above and beyond. What can we do to help you win the job? We can provide Building Information Modeling (BIM) files for Revit®, full CAD drawings in multiple views, photo-quality color renderings of the console design and even animated “walk-through” videos of the proposed installation.



WORLD CLASS CUSTOMER SERVICE

Our goal is to provide the best customer service in the industry; it is what our success is built on. Your satisfaction is guaranteed. Our experienced and knowledgeable customer service staff is ready to respond before, during and after the sale. We also stand by our products, which is why most of them carry a lifetime warranty. See **page 71** for Winsted's Warranty.

LET WINSTED DESIGN A CONSOLE FOR YOU: winsted.com/designservice

WELS™ 4

WINSTED EQUIPMENT LAYOUT SOFTWARE



THE MOST ADVANCED CONSOLE DESIGN SOFTWARE IS HERE!

WELS™ IS A WINSTED-EXCLUSIVE CONSOLE DESIGN SOFTWARE TOOL THAT MAKES CONTROL ROOM DESIGN AND LAYOUT FAST, EASY, ACCURATE AND FUN!

This interactive, user-friendly, 3D console design software program lets you use Winsted consoles and furniture to quickly design control room solutions that meet your needs. WELS is easy to use - and requires no additional design/ CAD software to operate.

WELS4 FEATURES

- WELS 4 is a FREE Winsted-exclusive tool. With it you can design your control room with any of our Consoles and Desks, Vertical Racks, M-View Monitor Walls and Conference Room Tables.
- On-screen toolbars and windows allow quick selection of products and accessories.
- Built-in control room designer lets you create a room to match your exact floor plan.
- Generate part lists and design specification sheets.
- Place multiple consoles and command centers anywhere in the room.
- Change the color of the work surface and side panels to show how the console will look in your room.
- Smart design programming helps you place parts where they belong.
- Accessorize designs with monitors, LCDs, DVD players, keyboards, blank panels, doors and more.
- WELS 4 is a true 3D design program. You can view your designs from any vertical or horizontal angle.
- WELS is a stand-alone program requiring no additional software.
- Export your design to DWG or DXF to import into your CAD program or export to JPEG format to use in presentations and design discussions.

WELS4 SYSTEM REQUIREMENTS:

Operating System: Microsoft Windows - Windows XP - or newer



DOWNLOAD WINSTED'S EQUIPMENT LAYOUT SOFTWARE AT: winsted.com/WELS



WINSTED HEADQUARTERS
 10901 HAMPSHIRE AVE. S.
 MINNEAPOLIS, MN 55438-2385 USA

CUSTOMER#

DEPT. CODE



WINSTED.COM

HELP STOP WASTEFUL DUPLICATE MAILINGS

If you receive duplicates of the same brochure with different customer numbers, please send us the labels. Indicate the correct label and we will update our records. Thanks for your help.

FOR THE WINSTED DEALER NEAREST YOU
 Call 1.800.447.2257 Or Fax 1.800.421.3839



winsted.com | info@winsted.com



STOCK • CUSTOMIZED • CUSTOM

WINSTED WORLD HEADQUARTERS

10901 Hampshire Avenue South
 Minneapolis, MN 55438-2385 USA

TEL: 800.447.2257 • 952.944.9050

FAX: 800.421.3839 • 952.944.1546

EMAIL: info@winsted.com

WEB: winsted.com

WINSTED CUSTOM DIVISION

1750 Breckinridge Pkwy, Suite 100
 Duluth, GA 30096-7576 USA

TEL: 800.237.5606 • 770.840.0880

FAX: 770.840.9685

EMAIL: custom@winsted.com

WEB: winstedcustom.com

WINSTED EUROPE • MIDDLE EAST

Unit D1 Sapphire Court
 Isidore Rd, Bromsgrove Enterprise Park
 Bromsgrove B60 3FL - UK

TEL: 44 (0) 1527 833714

EMAIL: info@winsted.co.uk

WEB: winsted.com